

Single Ear Stainless Steel Stirrup Bracket

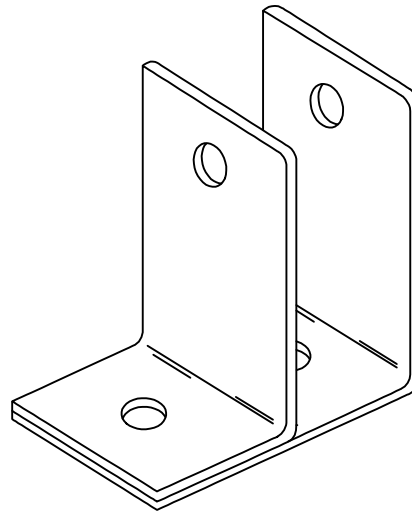

Sample Elevation

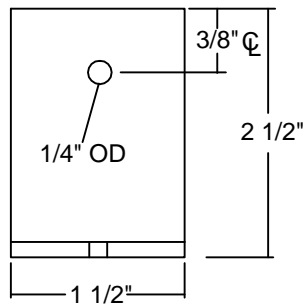
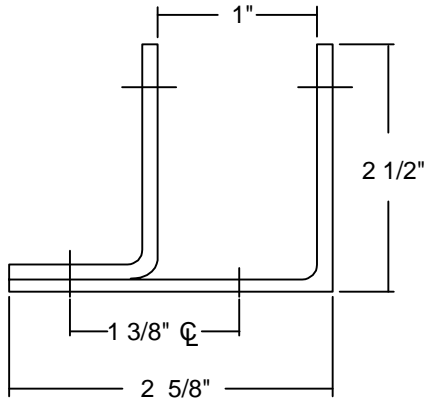
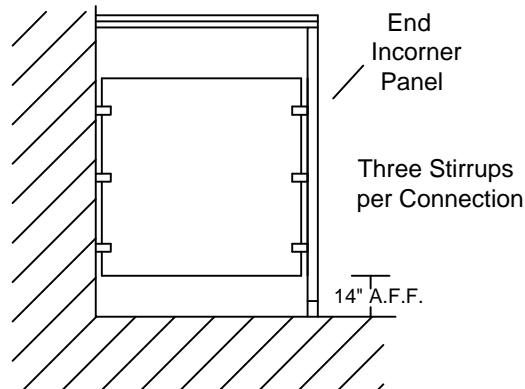

- **Material:** 14 ga. Stainless Steel, #4 Satin Finish.
- **Application:** Wall-to-panel connections; panel-to-pilaster connections. Three per connection.
- **Fasteners required per component:** (2) 1 1/2" Torx screws **or** (2) 3/4" Torx screws; (1) male/female thru-bolt pair.

Double Ear Stainless Steel Stirrup Bracket

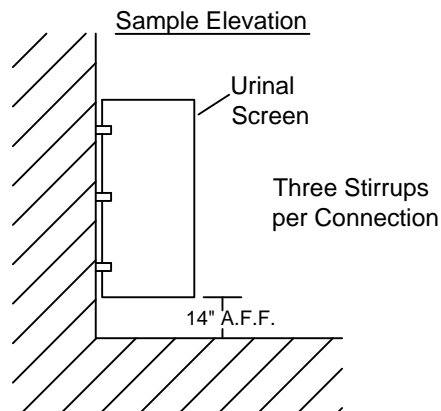
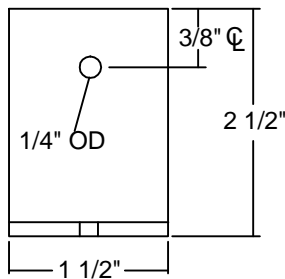
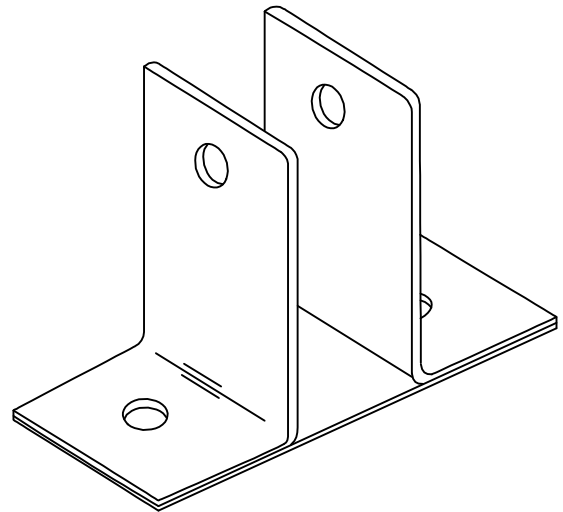
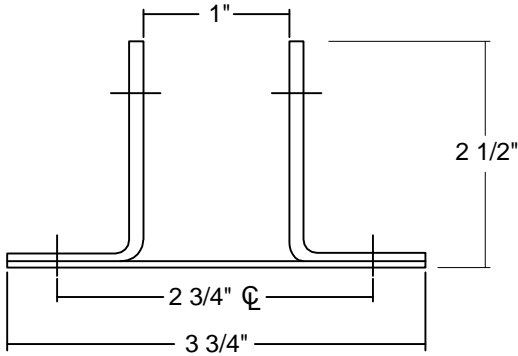

- **Material:** 14 ga. Stainless Steel, #4 Satin Finish.
- **Application:** Wall-to-panel connections; panel-to-pilaster connections. Three per connection.
- **Fasteners required per component:** (2) 1 1/2" Torx screws **or** (2) 3/4" Torx screws; (1) male/female thru-bolt pair.