

JOB #:

ITEM #:

QUANTITY:

MOUNTING	HANDING	TYPE	SIZE	OTHER

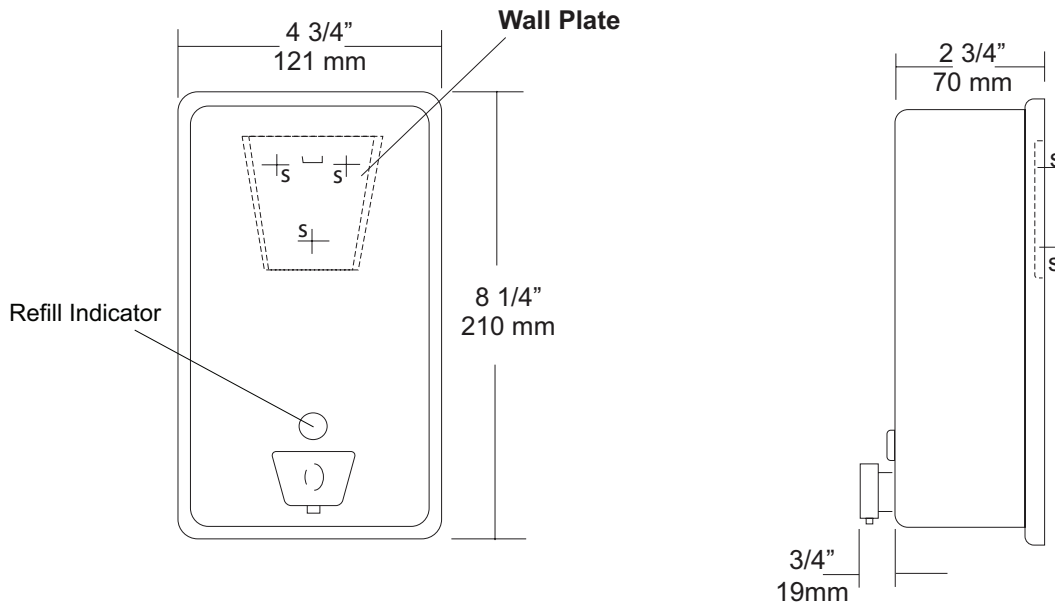

### SPECIFICATIONS

**Soap Tank:** Fabricated of #20 ga stainless steel, #4 satin finish, fully welded one-piece construction.

**Valve:** All purpose antibacterial soap valve cylinder, black molded plastic push style valve that takes less than 5 lbs of force and one hand to operate complies with barrier free guidelines when mounted at proper height.

**Viewer:** Clear plastic window allows a constant fluid level check.

**Concealed Mounting Plate:** Fabricated of heavy gauge stainless steel.

**Filler Cap:** Fabricated of stainless steel, hinged to allow easy servicing, secured with special key that creates a vandal resistant dispenser.

**Overall Size:** 4 3/4"W x 8 1/4"H x 3 1/2 (wall to valve)

**121mm x 210mm x 127mm**

**Capacity:** 40 oz.

**Recommend type soaps without chloric solutions for proper operation.**

### INSTALLATION

Provide an area on mounting surface at desired or specified location. Secure concealed mounting plate to wall surface with proper fasteners. Slide dispenser down over mounting plate and secure by means of set screw located inside tank. Fill unit with proper soap. Close lid and secure with special key. Test valve for proper operation.

\*It is not recommended to mount any soap dispenser on mirrors

\*\*For best performance, use pre-mixed low concentrate solutions. Dispensers should have periodic maintenance performed to insure the life dispenser. Rinse out globe and valve with warm water to avoid sludge buildup.

Preventative Maintenance: Each dispenser should be flushed out aprx. Every 30 days with warm water to prevent valve from clogging with old soap. Do not use abrasive cleaners to clean dispenser.

### NOTES

JOB #:

ITEM #:

QUANTITY:

MOUNTING	HANDING	TYPE	SIZE	OTHER

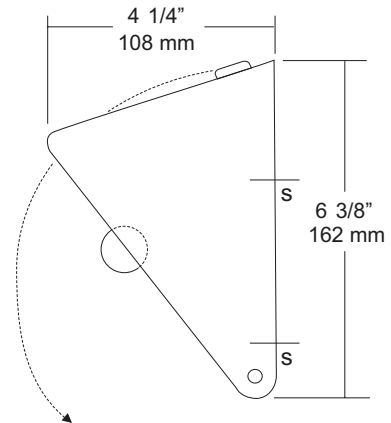
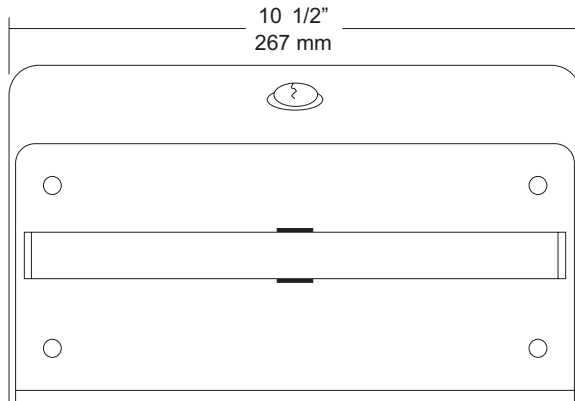

**SPECIFICATIONS**

**Hood:** Fabricated of #18 gauge stainless steel with a #4 satin finish on all exposed surfaces. Radius corners and leading edges are deburred. Keyed hood provides a theft resistant dispenser. Rolls cannot be removed without opening dispenser.

**Back Plate:** Fabricated of #22 gauge stainless steel.

**Roller:** Stainless steel roller is welded to a stainless steel post that has a capped end to prevent damage to roll.

**Locks:** commercial quality pin tumbler lock keyed like all other AJW accessories.

**Overall Size:** 10 1/2"W x 6 3/8"H x 4 1/4"D

**267mm x 161mm x 108mm**

**Capacity:** Two standard rolls with a 5 1/4" (133mm) OD.

**Options:**

-TK: Keyless twist lock.

**INSTALLATION**

Open hood of dispenser and place unit on mounting surface at desired or specified location. Making sure unit is level transfer mounting points to surface using unit as a template. Drill pilot holes and secure unit with proper fasteners per application. Install roll of toilet tissue and secure cover.

Toilet Paper Dispensers: All dispensers that are to meet ADA code cannot have any type of controlled delivery. (4.16)

**NOTES**



# U851 Seat Cover Dispenser

Revision 03/11

JOB #:

ITEM #:

QUANTITY:

MOUNTING	HANDING	TYPE	SIZE	OTHER

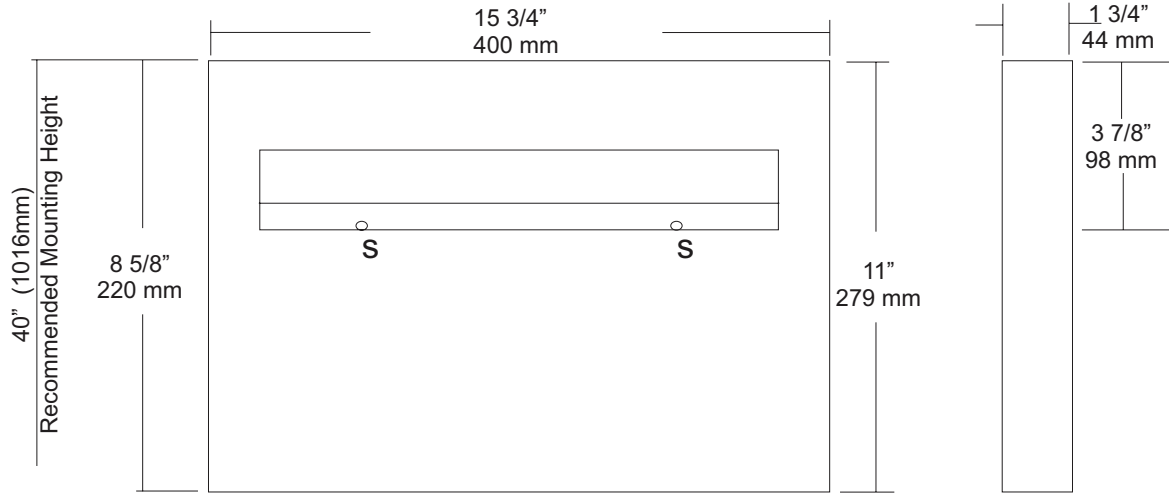

### SPECIFICATIONS

**Dispenser:** Unit is fabricated of #22 gauge stainless steel with a #4 satin finish. Beveled edge around the dispensing areas ensures a clean dispensing area that prevents product from tearing and injury. Loading of product is accomplished from below without having to open any locking mechanism or access panel. Hat style mounting bracket provides added rigidity for body and acts as a support for the packaging.

**Overall Size:** 15 3/4"W x 11"H x 1 3/4"D

**400mm x 279mm x 44mm**

**Capacity:** 500 seat covers

### INSTALLATION

Place unit on wall surface at desired or specified location making sure unit is level. Transfer mounting point locations and drill pilot holes for mounting. Secure unit to surface with proper fasteners per application. Product loads from the bottom out of site from public view.

### NOTES



# UG2-A

Grab Bars

Revised 03/11

JOB #:

ITEM #:

QUANTITY:

MOUNTING	HANDING	TYPE	SIZE	OTHER

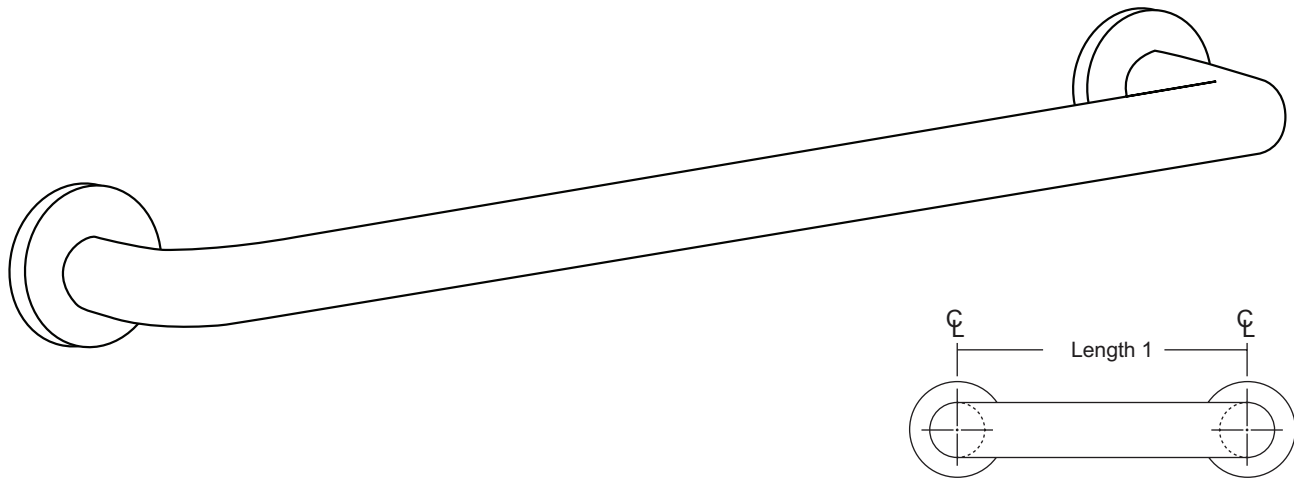

## SPECIFICATIONS & INSTALLATION

**Tubing:** Fabricated of #18 ga stainless steel with a #4 satin finish. Available in 1 1/4" outside diameter. All bends are formed by an automatic mandrel bending process. All bars maintain a constant 1 1/2" offset.

**Finish:** Standard finish is a #4 satin finish. For a non-slip finish (peened) add suffix X to model number. (Ex. UG2X-A)

**Flanges:** Snap flanges are fabricated of 3" diameter, 3/8" deep drawn #22 ga stainless steel with #4 satin finish to match tubing. Flanges have dimples that secure over mounting plate.

**Strength:** Bars with a 1 1/2" offset clearance will support loads in excess of 900lbs when properly installed. Bars with greater offsets will support loads up to 250lbs when properly installed.

**Installation:** Before installing grab bars, verify with all state and local codes for requirements on bar diameter and type finish. Recommended mounting heights for grab bars are 33" - 36" centerline above finished floor. All mounting of grab bars when possible should have in wall mounting back plates. Find centerline mounting points and place bar on line making sure to be on center. Transfer mounting points (3 per flange) to wall. Drill pilot holes and secure bar with proper anchors per application. Snap cover over mounting plate.

**Standard Lengths (Other sizes available upon request):** 12", 16", 18", 24", 30", 32", 36", 42", 48", 50", 52", 54", 56"

## FLANGE INFORMATION

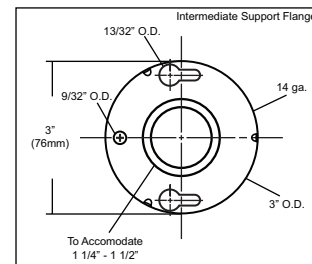
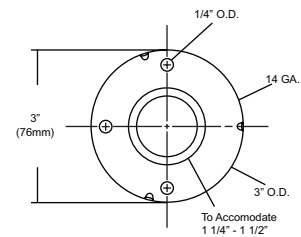
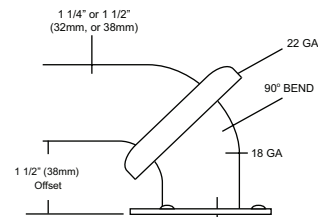

## NOTES



# UJ13 Series

## Mop Holder Strip & Shelf Combination Unit

Revision 03/11

JOB #:

ITEM #:

QUANTITY:

MOUNTING	HANDING	TYPE	SIZE	OTHER

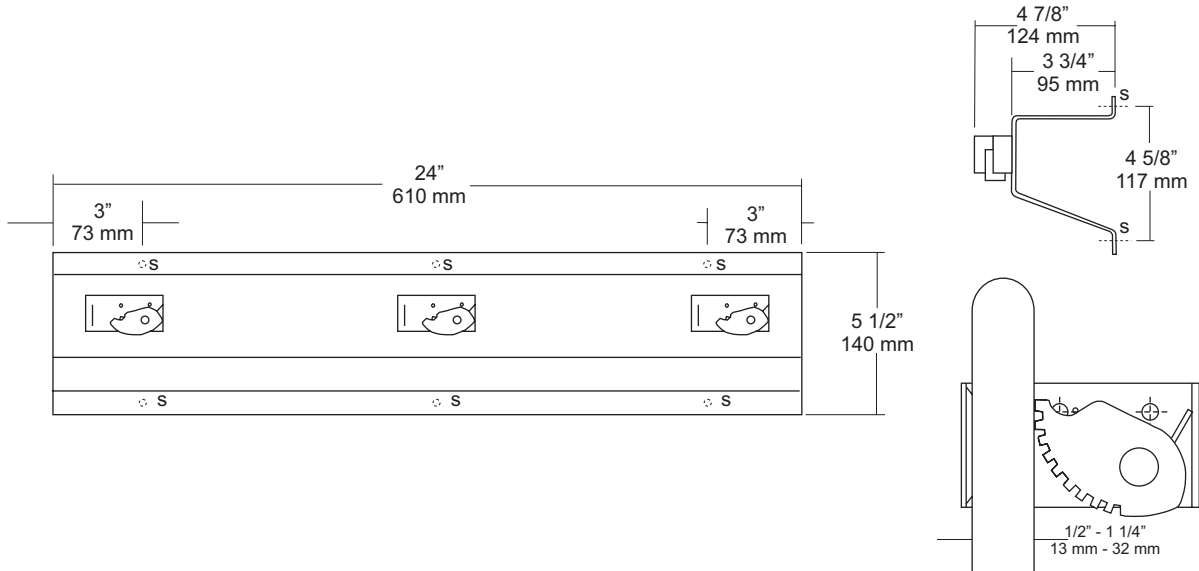

SPECIFICATIONS	INSTALLATION
----------------	--------------

**Mop Strip & Shelf:** Fabricated of #18 ga stainless steel with a #4 satin finish. Upper portion of strip is formed in the shape of a "hat" channel, that is utilized as a shelf, projects 3 3/4" from wall surface. Lower portion is angled to add rigidity and strength to strip.

**Mop Holders:** UJ19 plated reinforced steel with serrated cam type hard rubber mop or broom holder. Holds handles 1/2" to 1 1/4" diameter.

**Verify Style:**

- UJ13A:** 24"L (610mm) with 3 holders.
- UJ13B:** 36"L (914mm) with 4 holders.
- UJ13C:** 48"L (1219mm) with 5 holders.
- UJ13D:** 60"L (1524mm) with 6 holders.

Place unit to wall surface making sure unit is level and transfer mounting points. Drill pilot holes and secure unit with proper fasteners per application.

NOTES
-------

JOB #:

ITEM #:

QUANTITY:

MOUNTING	HANDING	TYPE	SIZE	OTHER

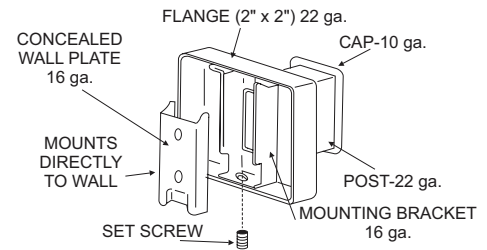
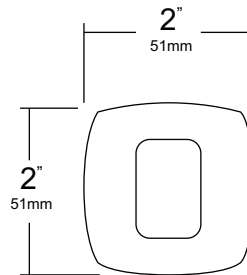
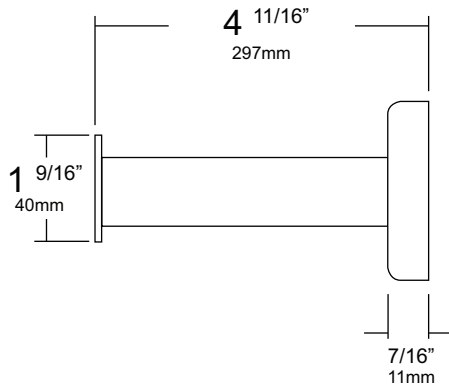

### SPECIFICATIONS

**UX Accessories:** All UX bath accessories series are fabricated of stainless steel with a bright or satin finish. Mounting plates are concealed with a snap-on type plate secured by a set screw.

**Hook:** #10 ga stainless steel hook

**Flange:** 2" x 2" flange #22 ga stainless steel.

**Post:** #22 ga stainless steel.

**Mounting Plate:** #16 ga concealed wall plate. Set screw secures mounting plate and flange.

**Overall Size:** 2"W x 2"H x 4 11/16"D

**51mm x 51mm x 120mm**

**UX111-SF:** Same as UX111-BF only satin finish in lieu of a bright finish stainless steel.

### INSTALLATION

Provide an area on wall surface at desired or specified location. Place concealed mounting plate on wall surface and transfer mounting points. Drill pilot holes and secure with proper fasteners. Place snap on flange over plate and secure with set screw.

### NOTES