

MOUNTING	HANDING	TYPE	SIZE	OTHER
----------	---------	------	------	-------

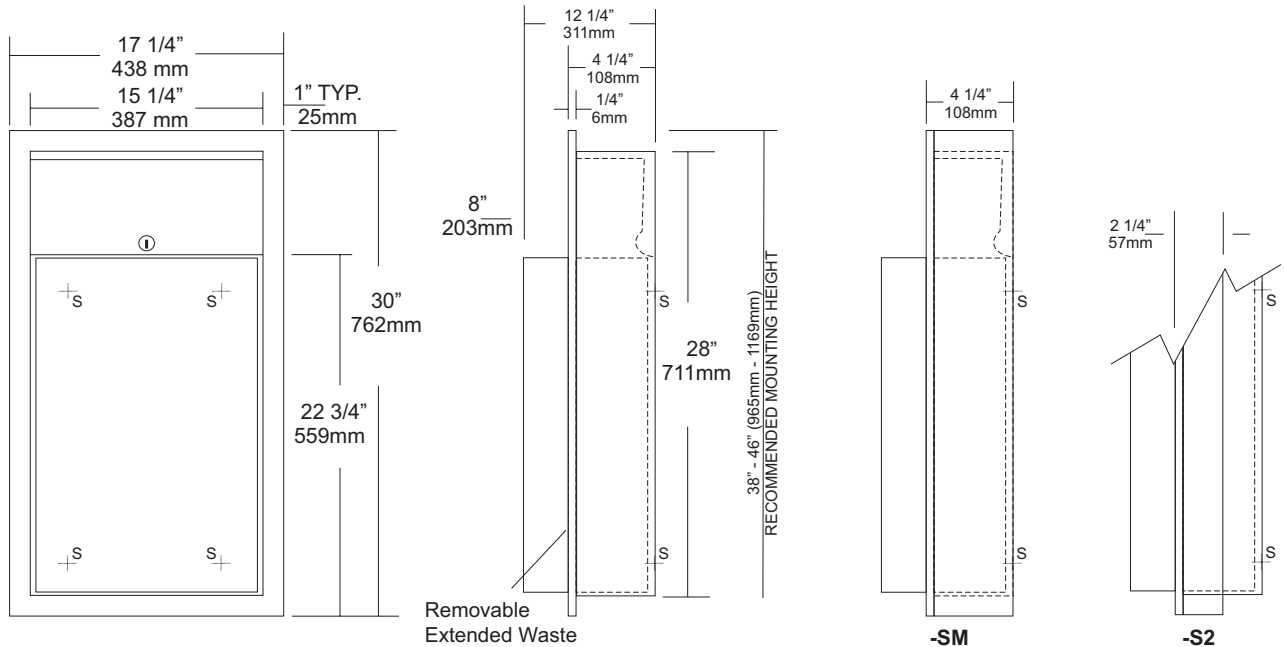

SPECIFICATIONS

Body: Fabricated of #22 ga stainless steel with #4 satin finish on all exposed areas.

Flange: Fabricated of #22 ga stainless steel finished to match cabinet. One piece construction without miters or welds with 1/4" returns to wall surface for maximum strength.

Back: Fabricated of stainless steel formed for rigidity with multiple welds to cabinet body to form a one-piece construction.

Removable Waste: Fabricated of #22 ga stainless steel with #4 satin finish with hemmed edges and radius corners. Hook tabs allow liner to be installed are an integral part of waste can. Waste is secured in place by tumbler lock and bottom hanger.

Lock: Pin tumbler, commercial quality, keyed like all other AJW cabinets.

Collars: #22 ga stainless steel, sized & finished to match cabinet. (Used for surface mounting & semi-recessing)

Overall Size: 17 1/4"W x 30"H x 12 1/4"D (8" ext. waste)
438mm x 762mm x 305mm

Wall Opening: 15 3/4"W x 28 1/2"H x 4"D
400mm x 724mm x 102mm

U412-S2: semi-recessed 2" collar(2" wall open.,51mm)

U412-SM: Surface mounting collar

Waste Capacity: 18 gallons (2.4 cu ft)

Options:

- VL2: Re-usable vinyl liner
- CV: Covered Waste

INSTALLATION

Coordinate installation with architect and contractor. Provide a wall opening 15 3/4"W x 28 1/2"H . Wall depth will vary if collars are required. Remove waste from cabinet and insert into opening. Secure unit with proper fasteners for each application. Make sure each unit is plumb and true. Secure unit in cabinet by locking in place by tumbler lock. Liners may be installed. (VL2 Re-usable liner If semi-recessed cabinets are required see specification for wall depth's.

NOTES

JOB #:

ITEM #:

QUANTITY:

MOUNTING	HANDING	TYPE	SIZE	OTHER
----------	---------	------	------	-------

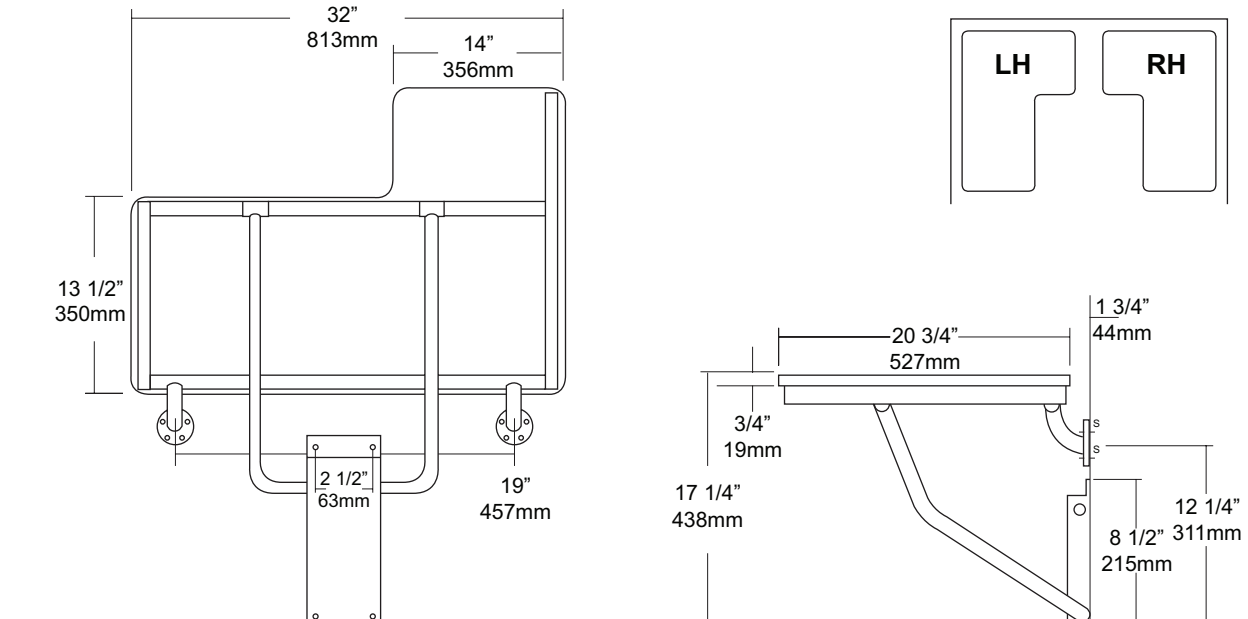

SPECIFICATIONS

Seat: Fabricated of 3/4" thick, one piece polymers (white) with all leading edges having a radius to prevent injury. Seat is secured to frame with carriage bolts and acorn nuts. Seat is reversible and handing is not required

Tubing: Fabricated of #18 ga stainless steel with #4 satin finish.

Main Frame: 1 1/4" diameter square tubing with capped ends.

Flanges: #18 gauge stainless steel with exposed mounting points. Under slung supports have a 1 1/4" OD

Supports: #18 ga stainless steel 1 1/4" dia diagonal stainless steel support guides for raising and lowering of seat.

Mounting Bracket: #18 gauge stainless steel "hat" style bracket with four (4) mounting points. Bracket acts as a guide for raising and lowering of seat. For maximum support, bracket is mounted resting on floor absorbing load transfer. Seat will remain in an upright position when not in use by means of a spring clip. Seat has been tested to maintain a 500 lb static load.

Overall Size: 32"W x 20 3/4"D (seating area)

813mm x 514mm

***Wall to floor mounting design provides equal distribution of weight to ensure safe operation.**

INSTALLATION

To comply with ADA Code, seat should be mounted at a height between 17" - 19" above finished floor. Check all state and local codes for building requirements.. Recommend in wall mounting on all shower seats. (BP10) Place seat up against wall making sure the extended part of seat has an offset no more than 1 1/2" away from wall. (Same as grab bar) Transfer mounting points to wall surface and drill pilot holes. Secure seat to surface with proper fasteners for each application. Snugly secure seat to surface and check seat to be level. If seat is level raise and lower seat to check path of travel. Finish securing seat after checking seat for proper operation. When properly mounted seat will support up to 750 lbs and will conform with ADA Code 4.21.3 and 4.26.3. To change handing, remove carriage bolts, switch square length tubing to opposite side and flip deck to change handing and secure with carriage bolts to framing.

NOTES