

JOB #:

ITEM #:

QUANTITY:

| MOUNTING | HANDING | TYPE | SIZE | OTHER |
|----------|---------|------|------|-------|
|----------|---------|------|------|-------|

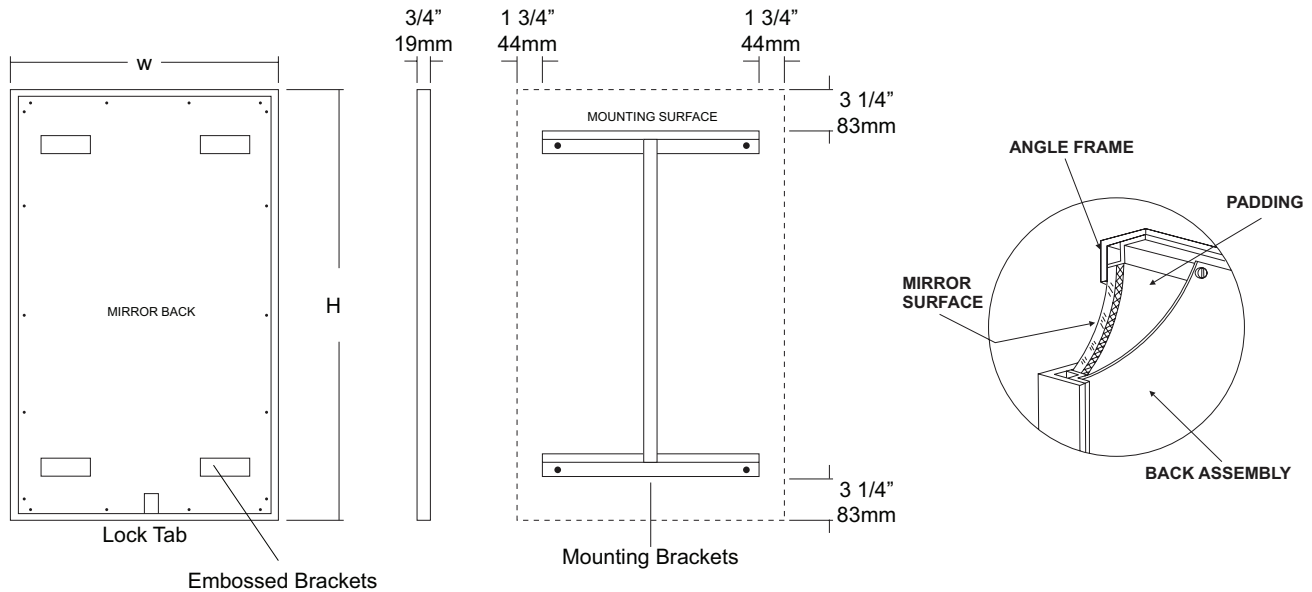

### SPECIFICATIONS

**Frame:** Fabricated of #18 ga stainless steel, #4 satin finish. 3/4" x 3/4" frame with welded mitered corners are ground and polished smooth. #22 ga concealed "Z" channel is spot welded to inner perimeter of frame for reinforcement and greater rigidity.

**Mirror:** 1/4" thick type 1 transparent flat type, class 1 - clear glass mirrors. Mirror is coated with silver and sealed with a uniform electrolytic copper plating, along with two coats of paint for added protection. Mirrors are guaranteed against silver spoilage for a period of 15 years. Mirrors conform to ASTM C1036 and ASTM C1503-R8.

**Filler:** 3/16" thick full size, shock absorbing, water resistant, non-abrasive polyethylene padding protects all concealed mirror surfaces.

**Back:** #20 ga pre-plated galvanized steel, with embossed horizontal louver mounting brackets. Embossed theft resistant pressure activated clip lock device, locks mirror in place to wall hangers. Back is secured to frame with concealed Phillips head screws.

**Hangers:** Fabricated of #20 ga pre-plated steel galvanized steel with mounting points.

**Standard Sizes Available (W x H):** 16"x24", 16"x20", 16"x30", 18"x24", 18"x30", 18"x36", 20"x60", 24"x30", 24"x36", 24"x42", 24"x48", 24"x60", 24"x72", 18"x60", 24"x60", 18"x72"

**Mirrors conform to Federal Specifications DD-M-00411b & DDg- 541D.**

**Options:**

**VC:** Safety Glass(Vinyl clad)

**T:** Tempered Glass

**LG:** Laminated Glass

**PM:** Plastic Acrylic

**8B:** #8 Reflective s/s

**LX:** Polycarbonite

**Recommended max size-8B mirrors:** 72" x 47 1/2"

**Mirrors are always ordered Width x Height**

**Framed mirrors are fabricated to a tolerance of +/- 1/8".**

### INSTALLATION

Coordinate installation with architect / contractor for specific mounting location and height for each mirror application. Making sure "I" bracket is level, transfer all mounting point locations to wall surface from drawing. Secure brackets with proper fasteners for each application. Slide mirror down over horizontal brackets until clip lock secures mirror in place. Mirror can only be removed by inserting tool through hole at bottom of frame depressing clip. This will allow mirror to slide up over brackets. Fillers are available if mirrors are mounted above and below tile line. (U004 Filler) filler material will match mirror frame to form a one piece construction.

To meet ADA Code, bottom edge of reflective surface can be no higher than 40" above finished floor. (4.19.6) Full length mirrors may be used for universal application when installed in correct locations.

Abrasive cleaners & chloric solutions should not be used on mirrors. Discoloring and /or scratching of frame and reflective surface may occur.

### NOTES



**U7712 Series**  
Surface Mounted Shelf

Revision 07/11

JOB #:

ITEM #:

QUANTITY:

| MOUNTING | HANDING | TYPE | SIZE | OTHER |
|----------|---------|------|------|-------|
|          |         |      |      |       |

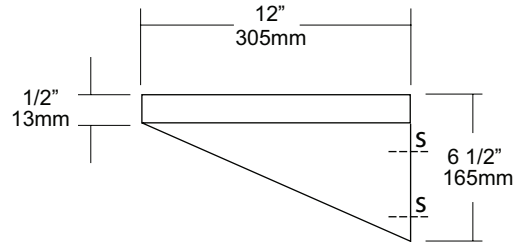
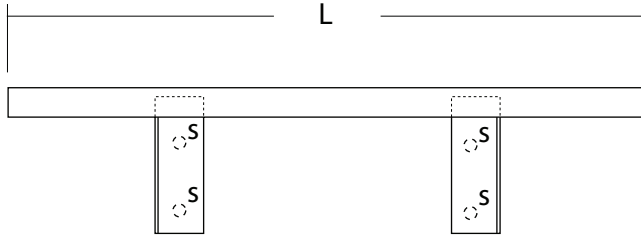

**SPECIFICATIONS**

**Shelves:** Fabricated of #18 ga stainless steel. All edges are turned down 1/2" with front edges turned down & back 1/2" for maximum strength and rigidity. All corners are deburred and polished smooth for safety.

**Brackets:** Fabricated of #16 ga stainless steel permanently welded to shelf with exposed mounting points. Brackets are spaced maximum 30" centerline.

**Surface mounted shelf 12"D. (305mm)**

**INSTALLATION**

Provide an area on wall surface at desired or specified location. Place unit up to wall making sure unit is level. Transfer mounting points to surface and drill pilot holes. Secure shelf to surface with proper fasteners per each application.

**NOTES**

JOB #:

ITEM #:

QUANTITY:

| MOUNTING | HANDING | TYPE | SIZE | OTHER |
|----------|---------|------|------|-------|
|          |         |      |      |       |

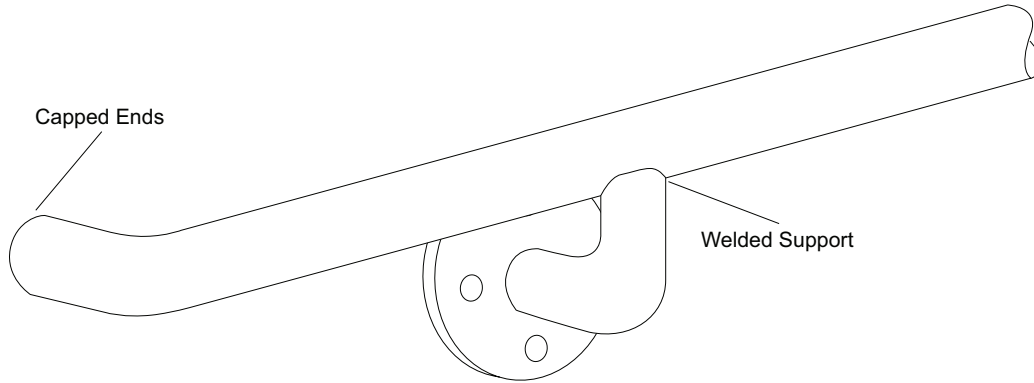

### SPECIFICATIONS & INSTALLATION

**Tubing:** Fabricated of #18 ga stainless steel with a #4 satin finish. Available in 1 1/4" outside diameter. All bends are formed by an automatic mandrel bending process. All bars maintain a constant 1 1/2" offset.

**Finish:** Standard finish is a #4 satin finish. For a non-slip finish (peened) add suffix X to model number. (Ex. UG120X-Y)

**Flange:** Fabricated of 3" diameter, #11 ga stainless steel with #4 satin finish to match tubing. Flanges are heliarc welded to bar to form a one piece construction. Each flange has three (3) mounting points (1/4" dia.)

**Strength:** Bars with a 1 1/2" offset clearance will support loads in excess of 900lbs when properly installed. Bars with greater offsets will support loads up to 250lbs when properly installed.

**Installation:** Before installing grab bars, verify with all state and local codes for requirements on bar diameter and type finish. Recommended mounting heights for grab bars are 33" - 36" centerline above finished floor. All mounting of grab bars when possible should have in wall mounting back plates. Find centerline mounting points and place bar on line making sure to be on center. Transfer mounting points (3 per flange) to wall. Drill pilot holes and secure bar with proper anchors per application.

**Standard Lengths (Other sizes available upon request):** 60", 72", 84", 96", 108", 120"

### FLANGE INFORMATION

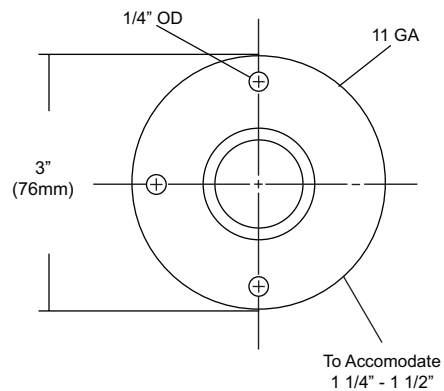
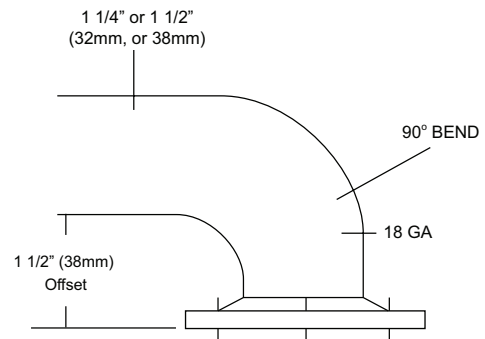

JOB #:

ITEM #:

QUANTITY:

| MOUNTING | HANDING | TYPE | SIZE | OTHER |
|----------|---------|------|------|-------|
|          |         |      |      |       |

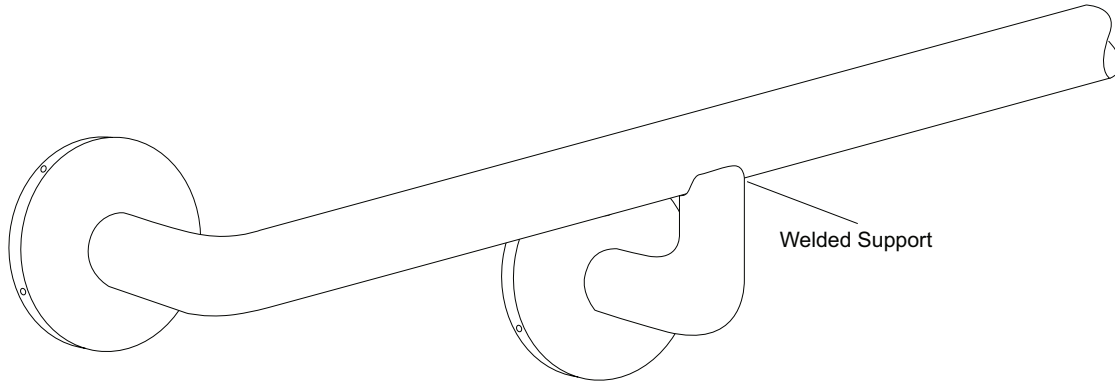

### SPECIFICATIONS & INSTALLATION

**Tubing:** Fabricated of #18 ga stainless steel with a #4 satin finish. Available in 1 1/4" outside diameter. All bends are formed by an automatic mandrel bending process. All bars maintain a constant 1 1/2" offset.

**Finish:** Standard finish is a #4 satin finish. For a non-slip finish (peened) add suffix X to model number. (Ex. UG20X-Z)

**Flange:** Flanges are fabricated of 3" diameter, 1/2" drawn #11 ga stainless steel with #4 satin finish to match tubing. Flanges are heliarc welded to bar to form a one piece construction. Each flange is secured to concealed mounting plate with four (4) 1/4"-20 stainless steel tamper resistant set screws.

**Strength:** Bars with a 1 1/2" offset clearance will support loads in excess of 900lbs when properly installed. Bars with greater offsets will support loads up to 250lbs when properly installed.

**Installation:** Before installing grab bars, verify with all state and local codes for requirements on bar diameter and type finish. Recommended mounting heights for grab bars are 33" - 36" centerline above finished floor. All mounting of grab bars when possible should have in wall mounting back plates. Secure mounting plate to wall surface at specified location with proper anchors (snugly) until proper centerline dimension is achieved. Place bar over plates and secure with supplied set screws. (4 per flange).

**Standard Lengths (Other sizes available upon request):** 60", 72", 84", 96", 108", 120"

### FLANGE INFORMATION

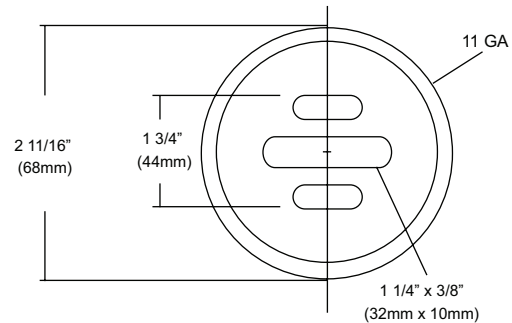
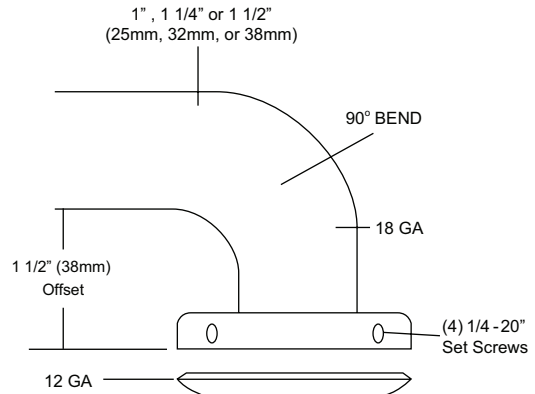

JOB #:

ITEM #:

QUANTITY:

| MOUNTING | HANDING | TYPE | SIZE | OTHER |
|----------|---------|------|------|-------|
|          |         |      |      |       |

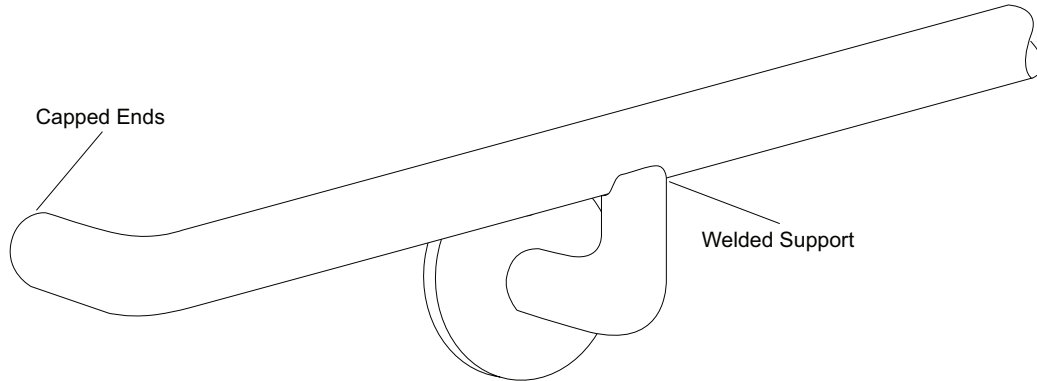

### SPECIFICATIONS & INSTALLATION

**Tubing:** Fabricated of #18 ga stainless steel with a #4 satin finish. Available in 1 1/2" outside diameter. All bends are formed by an automatic mandrel bending process. All bars maintain a constant 1 1/2" offset.

**Finish:** Standard finish is a #4 satin finish. For a non-slip finish (peened) add suffix X to model number. (Ex. UG3X-Y)

**Flanges:** Snap flanges are fabricated of 3" diameter, 3/8" deep drawn #22 ga stainless steel with #4 satin finish to match tubing. Flanges have dimples that secure over mounting plate.

**Strength:** Bars with a 1 1/2" offset clearance will support loads in excess of 900lbs when properly installed. Bars with greater offsets will support loads up to 250lbs when properly installed.

**Installation:** Before installing grab bars, verify with all state and local codes for requirements on bar diameter and type finish. Recommended mounting heights for grab bars are 33" - 36" centerline above finished floor. All mounting of grab bars when possible should have in wall mounting back plates. Find centerline mounting points and place bar on line making sure to be on center. Transfer mounting points (3 per flange) to wall. Drill pilot holes and secure bar with proper anchors per application. Snap cover over mounting plate.

**Standard Lengths (Other sizes available upon request):** 60", 72", 84", 96", 108", 120"

### FLANGE INFORMATION

