



Date

Project Name

Attn

From

Phone

Fax

Email

WASHROOM PARTITIONS | WASHROOM ACCESSORIES | STORAGE SYSTEMS | VISUAL DISPLAY PRODUCTS

509 TEMPLE HILL RD. NEW WINDSOR NY 12553 P. 845.562.3332 F. 845.562.3391 AJW.COM

U850

Seat Cover Dispenser

Revision 03/11

JOB #:

ITEM #:

QUANTITY:

Mounting	Handing	Type	Size	Other

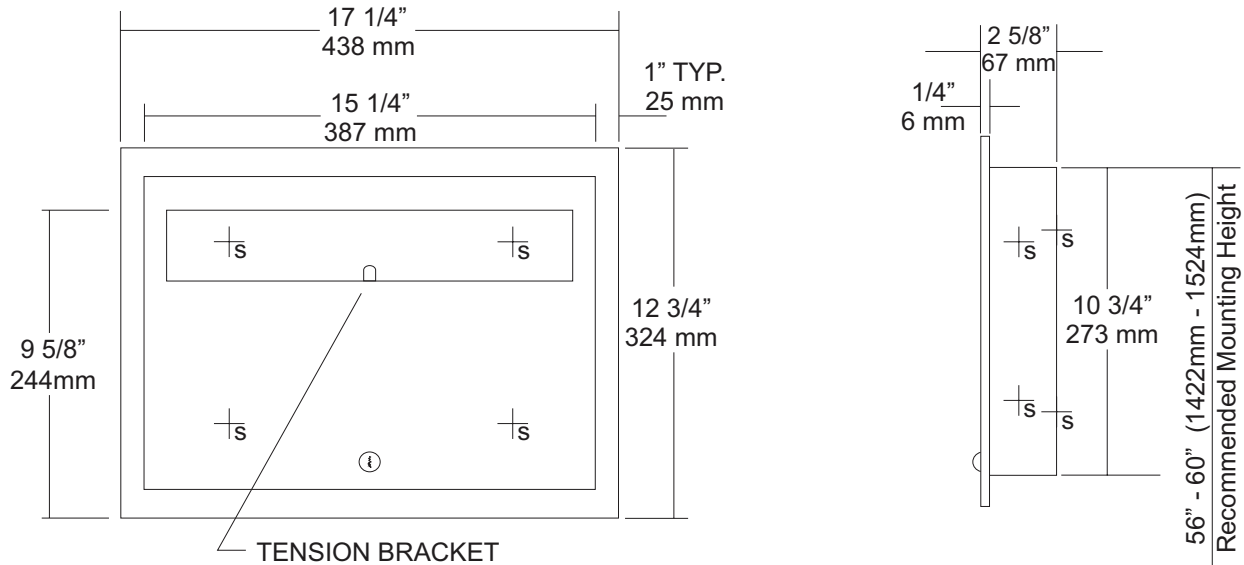

SPECIFICATIONS

Body: Fabricated of #22 gauge stainless steel with a #4 satin finish on all exposed surfaces.

Flange: #22 gauge stainless steel with 1/4" returns to wall without any miters.

Door: Fabricated of #22 gauge stainless steel with a #4 satin finish.

Locks: Pin tumbler, commercial quality locks keyed like all other AJW cabinets.

Overall Size: 17 1/4"W x 12 3/4"H x 2 5/8"D

438mm x 324mm x 68mm

Wall Opening: 15 3/4"W x 11 1/4"H x 2 3/8"D

400mm x 286mm x 60mm

U850-SM: Surface mounted unit

Capacity: 500 seat covers

INSTALLATION

Provide required wall opening at desired or specified location with coordination with architect or contractor to avoid interference with pipes, vents, etc. Unlock cabinet and place unit in opening. Secure to rough framing with proper fasteners per each application. Fill dispenser with product and secure cabinet door.

NOTES