



Date 20/15/0204
Project Name c31
Attn seoyeonpark
From
Phone
Fax
Email arch@cmctech.kr

WASHROOM PARTITIONS | WASHROOM ACCESSORIES | STORAGE SYSTEMS | VISUAL DISPLAY PRODUCTS

509 TEMPLE HILL RD. NEW WINDSOR NY 12553 P. 845.562.3332 F. 845.562.3391 AJW.COM



U921

Retractable Bariatric Shower Seat

Revision 03/11

JOB #:

ITEM #:

QUANTITY:

MOUNTING	HANDING	TYPE	SIZE	OTHER

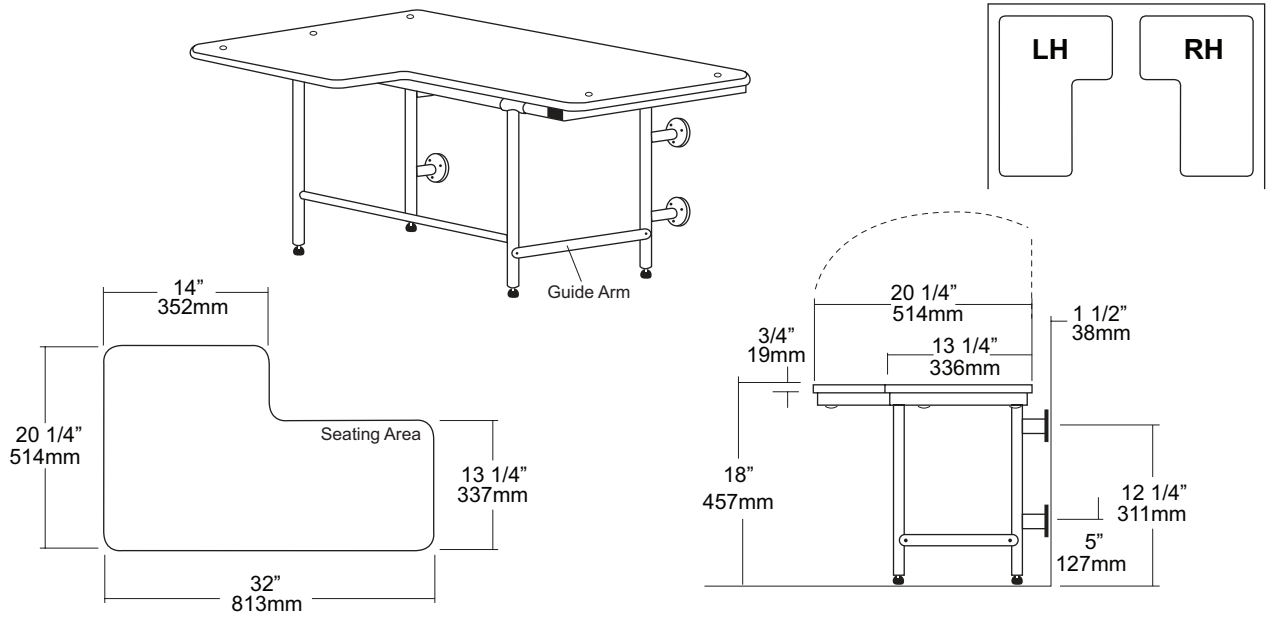

SPECIFICATIONS

- Seat:** Fabricated of 3/4" white polymer with all leading edges having a radius to prevent injury. Seat is secured to frame by means of countersunk carriage bolts and acorn nuts. Handing is reversible in the field.
- Tubing:** Fabricated of #18 gauge stainless steel with a #4 satin finish.
- Main Frame:** Fabricated of #18 gauge stainless steel, with satin finish, 1 1/4" square tubing with capped ends.
- Under Slung Supports:** Fabricated of satin finish stainless steel tubing welded to framing.
- Flanges:** #11 gauge steel satin finish (3" O.D.) with four (4) exposed mounting points.
- Support Legs:** Four (4) support legs are fabricated of #18 gauge stainless steel tubing with anti-slip support feet. Feet are adjustable by means of a threaded rod that allows minor adjustments for seat to be leveled due to a slope of the shower base.
- Shower Seat:** When mounted properly seat will be 18" above finished floor with a 1/2" adjustability to level seat. Wall / floor design provides maximum support and equal distribution of weight. Seat has been tested to maintain 1300 lbs of static load. Handing of seat can be changed in the field.
- Overall Size:** 32"W x 20 1/4"D (Seating Area) 813mm x 514mm

INSTALLATION

To comply with ADA code, seat (bench) should be mounted at a height 17" – 19" above the finished floor. Check all state and local codes for building requirements. Seat when mounted properly will have a height of 18" above finished floor. Place unit in the extended position at desired or specified location making sure the space between the wall and seating area is not greater than 1 1/2" and transfer mounting point locations to mounting surface and drill pilot holes. Snugly secure to surface with proper anchoring and check bench for level. If seat is not level, adjust accordingly with the threaded non-slip feat. Fold seat up to check travel of seat. Seat will remain in the retracted position when installed properly. Lower the seat to verify full leg extension, check seat to be level and finish securing fasteners.

NOTES