

MOUNTING	HANDING	TYPE	SIZE	OTHER
----------	---------	------	------	-------

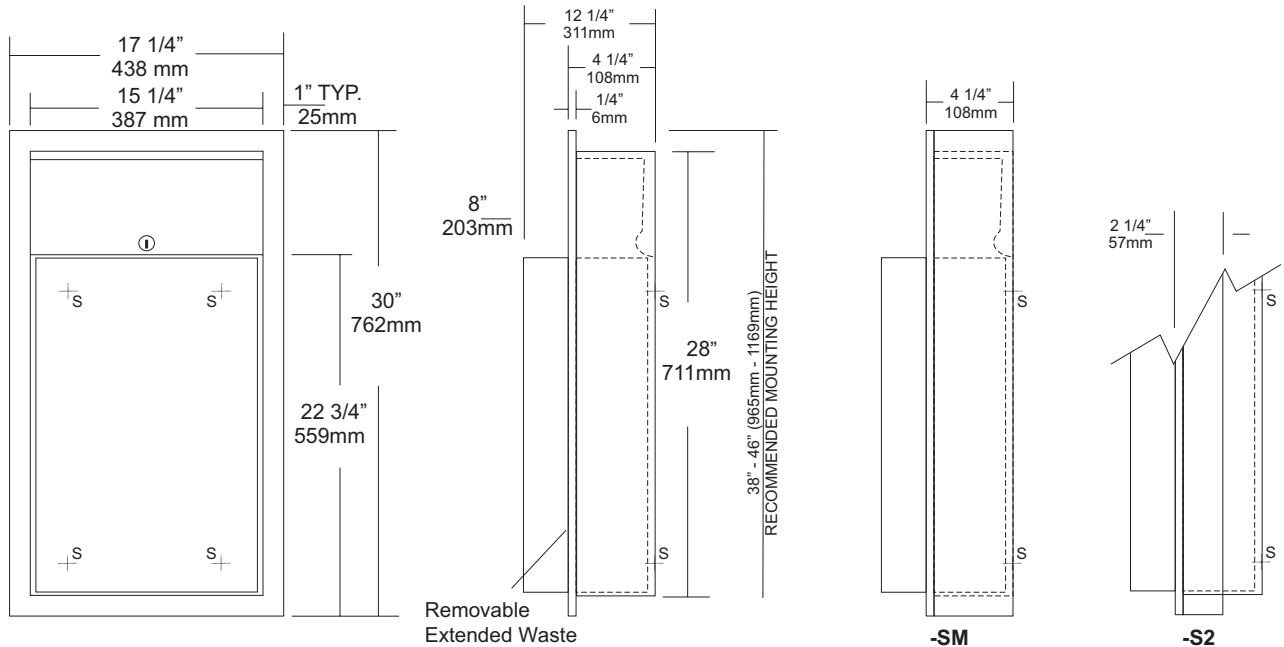

### SPECIFICATIONS

**Body:** Fabricated of #22 ga stainless steel with #4 satin finish on all exposed areas.

**Flange:** Fabricated of #22 ga stainless steel finished to match cabinet. One piece construction without miters or welds with 1/4" returns to wall surface for maximum strength.

**Back:** Fabricated of stainless steel formed for rigidity with multiple welds to cabinet body to form a one-piece construction.

**Removable Waste:** Fabricated of #22 ga stainless steel with #4 satin finish with hemmed edges and radius corners. Hook tabs allow liner to be installed are an integral part of waste can. Waste is secured in place by tumbler lock and bottom hanger.

**Lock:** Pin tumbler, commercial quality, keyed like all other AJW cabinets.

**Collars:** #22 ga stainless steel, sized & finished to match cabinet. (Used for surface mounting & semi-recessing)

**Overall Size:** 17 1/4"W x 30"H x 12 1/4"D (8" ext. waste)  
**438mm x 762mm x 305mm**

**Wall Opening:** 15 3/4"W x 28 1/2"H x 4"D  
**400mm x 724mm x 102mm**

**U412-S2:** semi-recessed 2" collar(2" wall open.,51mm)

**U412-SM:** Surface mounting collar

**Waste Capacity:** 18 gallons (2.4 cu ft)

**Options:**

- VL2: Re-usable vinyl liner
- CV: Covered Waste

### INSTALLATION

Coordinate installation with architect and contractor. Provide a wall opening 15 3/4"W x 28 1/2"H . Wall depth will vary if collars are required. Remove waste from cabinet and insert into opening. Secure unit with proper fasteners for each application. Make sure each unit is plumb and true. Secure unit in cabinet by locking in place by tumbler lock. Liners may be installed. (VL2 Re-usable liner If semi-recessed cabinets are required see specification for wall depth's.

### NOTES



A&J Washroom Accessories

### UX1A FLANGE & SHOWER ROD

Job #:

Item #:

Quantity:

MOUNTING	HANDING	TYPE	SIZE	OTHER

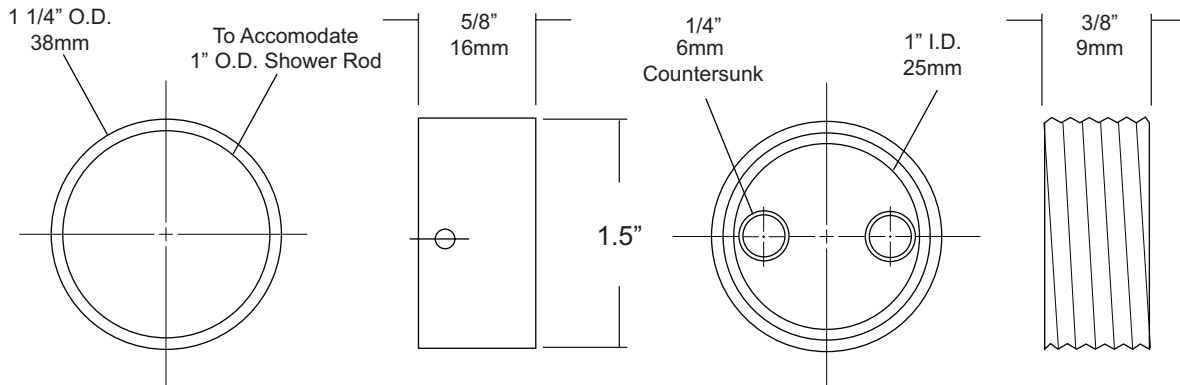

SPECIFICATIONS	INSTALLATION
----------------	--------------

**Cover:** Fabricated of chrome on brass, with concealed mounting.

**Shower Rod:** Fabricated of type 304 stainless steel with a #4 satin finish.

**UX1:** 1" outside diameter

**Provide an area on wall surface at desired or specified location. Hold flange to wall surface and transfer mounting points. Drill pilot holes. Place flanges on the ends of the rods. Secure flanges to wall surface with proper fasteners per application.**

#### NOTES