

## U125 Soap Dispenser

Revision 03/11

JOB #:

ITEM #:

QUANTITY:

MOUNTING	HANDING	TYPE	SIZE	OTHER

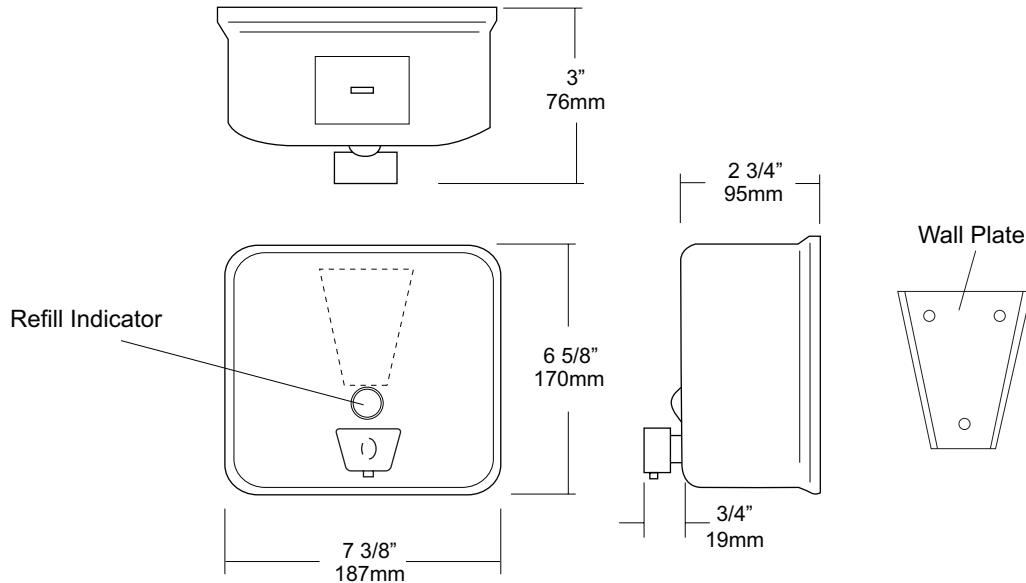

### SPECIFICATIONS

**Tank:** #20 ga stainless steel with satin finish, Drawn one piece construction with a curved front design and radius corners.

**Back:** #22 gauge stainless steel with #20 gauge stainless steel mounting plate attached. Back plate and tank are welded together to form a one piece unit

**Valve:** All purpose antibacterial soap valve cylinder, black molded plastic push style valve that takes less than 5 lbs of force and one hand to operate complies with barrier free guidelines when mounted at proper height.

**Refill Indicator:** Clear plastic viewer window allows a constant fluid level check.

**Filler Cap:** Fabricated of stainless steel, hinged to allow easy servicing, Cap is secured with special key that creates a vandal resistant dispenser.

**Overall Size:** 7 3/8"W x 6 5/8"H x 3 3/4"D

**188mm x 170mm x 95mm**

**Capacity:** 45 oz

### INSTALLATION

Provide an area on wall surface at desired or specified location, Secure concealed mounting plate to wall surface with proper fasteners, Slide dispenser down over mounting plate and secure by means of a set screw located inside the tank accessible by opening service lid, Fill unit with soap, Secure lid, Prime the valve and test for proper operation.

\*It is not recommended to mount any soap dispenser on mirrors

\*\*For best performance, use pre-mixed low concentrate solutions. Dispensers should have periodic maintenance performed to insure the life dispenser. Rinse out globe and valve with warm water to avoid sludge buildup.

Preventative Maintenance: Each dispenser should be flushed out aprx, Every 30 days with warm water to prevent valve from; clogging with old soap, Abrasive cleaners should not be used when wiping down dispenser.

### NOTES

MOUNTING	HANDING	TYPE	SIZE	OTHER

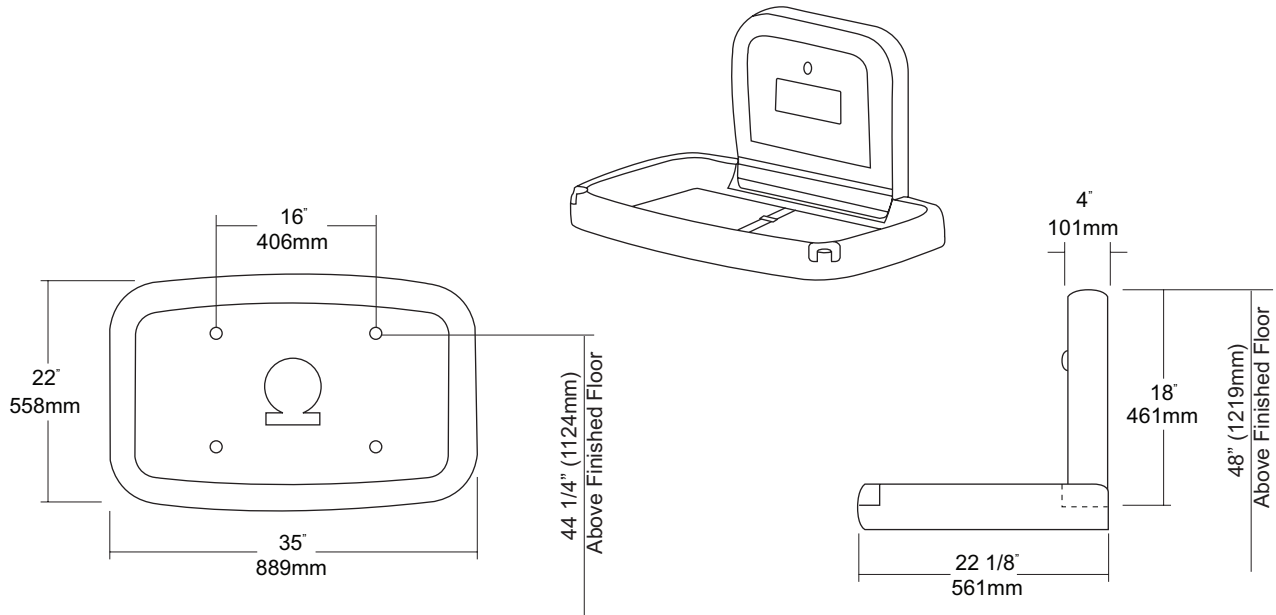

**SPECIFICATIONS**

**Body:** FDA approved injection molded polypropylene with Microban antimicrobial additive. Reinforced steel-on-steel hinge mechanism and metal mounting chassis. Labeled usage instructions and safety messages in four languages. (Braille label optional)

**Liner Dispenser:** An integral part of body that is standard with each unit. (Capacity: 50)

**Pneumatic Cylinder:** Provides slow opening and closing of bed. Complies with ASTM static loads when properly installed.

**Safety Straps:** Nylon safety strap snap lock fastens to hold child securely in place.

**Overall Size:** 35"W x 22"H x 4"D (closed) 22 1/8"D (open)

**889mm x 558mm x 102mm (closed), 561mm (open)**

**Available Colors:** Cream, Granite & Grey

**INSTALLATION**

Coordinate installation with architect or contractor to avoid interference with surrounding objects. Hold unit up to wall and open to verify there are no obstructions to interfere with operation of station. From finished floor to the top of the unit closed should be at a height of 48". Transfer mounting point locations to wall surface and drill pilot holes. Secure unit with proper fasteners for each application. (Recommend a qualified carpenter to install unit) Unit can be lowered with one hand and into position with less than 5 lbs of force, wall openingut turning or twisting of wrist. Verify with local codes and type approach (forward or side) for proper mounting height above finished floor. Unit can support up to 200lbs when properly installed.

Unit should be cleaned once or more daily with a clean nylon brush and spray disinfectant.

When properly installed, baby changing stations comply with ASTM static load performance requirements.

**NOTES**

Formerly Model #: U945H



# UJ13 Series

## Mop Holder Strip & Shelf Combination Unit

Revision 03/11

JOB #:

ITEM #:

QUANTITY:

MOUNTING	HANDING	TYPE	SIZE	OTHER

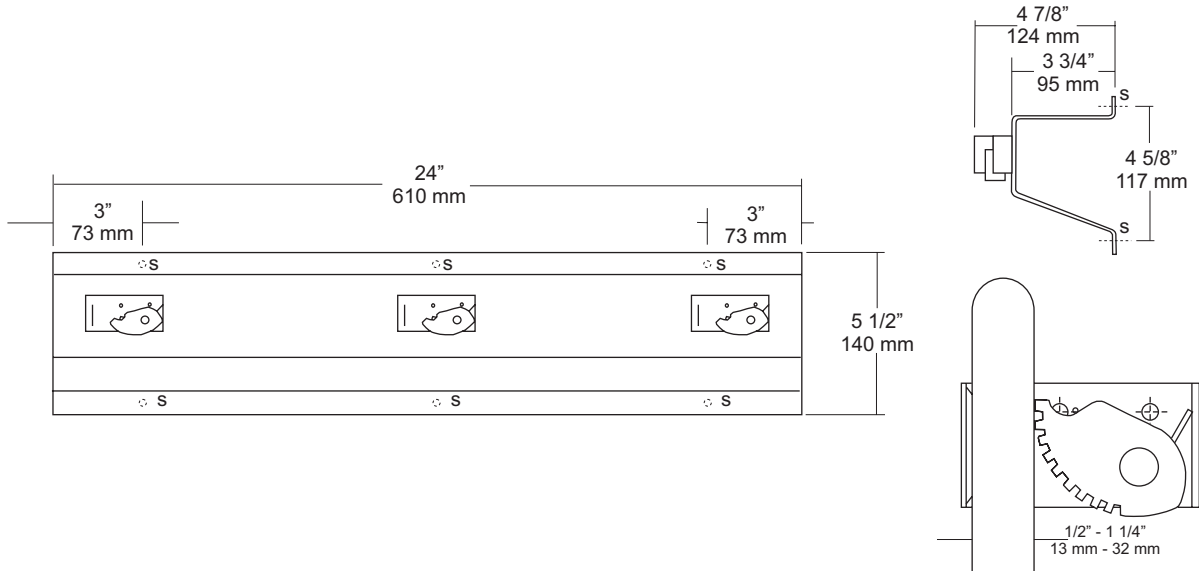

### SPECIFICATIONS

**Mop Strip & Shelf:** Fabricated of #18 ga stainless steel with a #4 satin finish. Upper portion of strip is formed in the shape of a "hat" channel, that is utilized as a shelf, projects 3 3/4" from wall surface. Lower portion is angled to add rigidity and strength to strip.

**Mop Holders:** UJ19 plated reinforced steel with serrated cam type hard rubber mop or broom holder. Holds handles 1/2" to 1 1/4" diameter.

**Verify Style:**

**UJ13A:** 24"L (610mm) with 3 holders.

**UJ13B:** 36"L (914mm) with 4 holders.

**UJ13C:** 48"L (1219mm) with 5 holders.

**UJ13D:** 60"L (1524mm) with 6 holders.

### INSTALLATION

Place unit to wall surface making sure unit is level and transfer mounting points. Drill pilot holes and secure unit with proper fasteners per application.

### NOTES

JOB #:

ITEM #:

QUANTITY:

MOUNTING	HANDING	TYPE	SIZE	OTHER

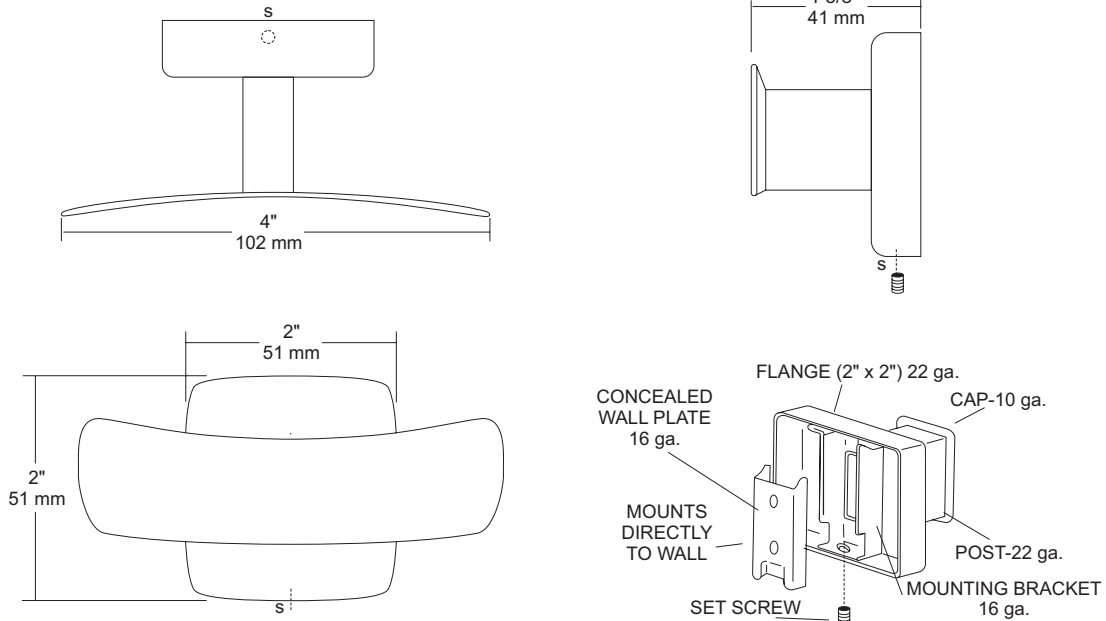

### SPECIFICATIONS

**UX Accessories:** All UX bath accessories series are fabricated of stainless steel with a bright or satin finish. Mounting plates are concealed with a snap-on type plate secured by a set screw.

**Hook:** #10 ga stainless steel hook

**Flange:** 2" x 2" flange #22 ga stainless steel.

**Post:** #22 ga stainless steel.

**Mounting Plate:** #16 ga stainless steel concealed wall plate. Set screw secures mounting plate and flange.

**Overall Size:** 4"W x 2"H x 1 5/8"D

**51mm x 51mm x 41mm**

**UX112-SF:** Same as UX112-BF with satin finish.

### INSTALLATION

Provide an area on wall surface at desired or specified location. Place concealed mounting plate on wall surface and transfer mounting points. Drill pilot holes and secure with proper fasteners. Place snap on flange over plate and secure with set screw.

### NOTES

**UX2K**  
 Flange & Shower Rod

Revision 03/11

JOB #:

ITEM #:

QUANTITY:

MOUNTING	HANDING	TYPE	SIZE	OTHER

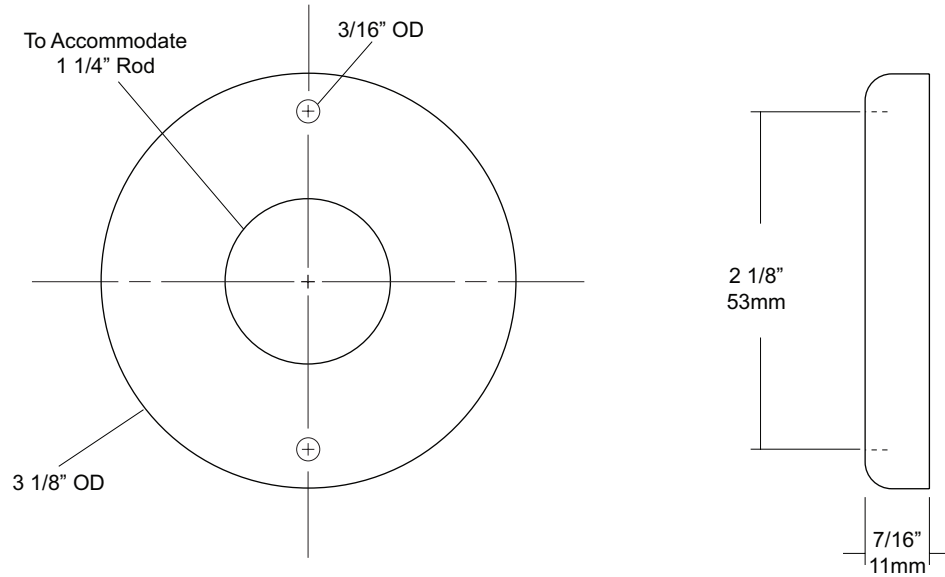

**SPECIFICATIONS**

**Exposed Cover:** Fabricated of #22 gauge stainless steel with a #4 satin finish. Cover has two (2) exposed mounting points.

**Shower Rod:** Fabricated of stainless steel with a #4 satin finish.

**UX2:** 1 1/4" outside diameter

**INSTALLATION**

Provide an area on wall surface at desired or specified location. Hold flange to wall surface and transfer mounting points. Drill pilot holes. Place flanges on the ends of the rods. Secure flanges to wall surface with proper fasteners per application.

**NOTES**