



Date 03/20/2014
Project Name Crestmoore Assisted Living Facility
Attn Tom K.
From Debi
Phone (845)346-4700
Fax (845)342-3381
Email tomk@eamorse.com

JOB #:

ITEM #:

QUANTITY:

MOUNTING	HANDING	TYPE	SIZE	OTHER
----------	---------	------	------	-------

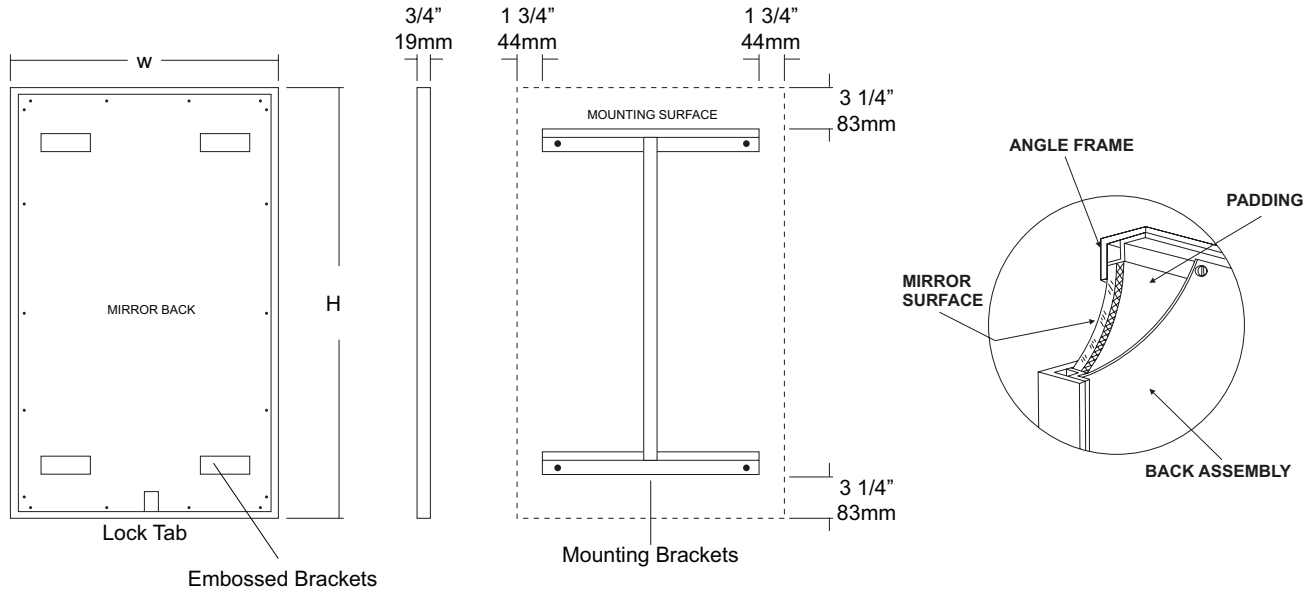

SPECIFICATIONS

Frame: Fabricated of #18 ga stainless steel, #4 satin finish. 3/4" x 3/4" frame with welded mitered corners are ground and polished smooth. #22 ga concealed "Z" channel is spot welded to inner perimeter of frame for reinforcement and greater rigidity.

Mirror: 1/4" thick type 1 transparent flat type, class 1 - clear glass mirrors. Mirror is coated with silver and sealed with a uniform electrolytic copper plating, along with two coats of paint for added protection. Mirrors are guaranteed against silver spoilage for a period of 15 years. Mirrors conform to ASTM C1036 and ASTM C1503-R8.

Filler: 3/16" thick full size, shock absorbing, water resistant, non-abrasive polyethylene padding protects all concealed mirror surfaces.

Back: #20 ga pre-plated galvanized steel, with embossed horizontal louver mounting brackets. Embossed theft resistant pressure activated clip lock device, locks mirror in place to wall hangers. Back is secured to frame with concealed Phillips head screws.

Hangers: Fabricated of #20 ga pre-plated steel galvanized steel with mounting points.

Standard Sizes Available (W x H): 16"x24", 16"x20", 16"x30", 18"x24", 18"x30", 18"x36", 20"x60", 24"x30", 24"x36", 24"x42", 24"x48", 24"x60", 24"x72", 18"x60", 24"x60", 18"x72"

Mirrors conform to Federal Specifications DD-M-00411b & DDg- 541D.

Options:

VC: Safety Glass(Vinyl clad)

T: Tempered Glass

LG: Laminated Glass

PM: Plastic Acrylic

8B: #8 Reflective s/s

LX: Polycarbonate

Recommended max size-8B mirrors: 72" x 47 1/2"

Mirrors are always ordered Width x Height

Framed mirrors are fabricated to a tolerance of +/- 1/8".

INSTALLATION

Coordinate installation with architect / contractor for specific mounting location and height for each mirror application. Making sure "I" bracket is level, transfer all mounting point locations to wall surface from drawing. Secure brackets with proper fasteners for each application. Slide mirror down over horizontal brackets until clip lock secures mirror in place. Mirror can only be removed by inserting tool through hole at bottom of frame depressing clip. This will allow mirror to slide up over brackets. Fillers are available if mirrors are mounted above and below tile line. (U004 Filler) filler material will match mirror frame to form a one piece construction.

To meet ADA Code, bottom edge of reflective surface can be no higher than 40" above finished floor. (4.19.6) Full length mirrors may be used for universal application when installed in correct locations.

Abrasive cleaners & chloric solutions should not be used on mirrors. Discoloring and /or scratching of frame and reflective surface may occur.

NOTES

MOUNTING	HANDING	TYPE	SIZE	OTHER
----------	---------	------	------	-------

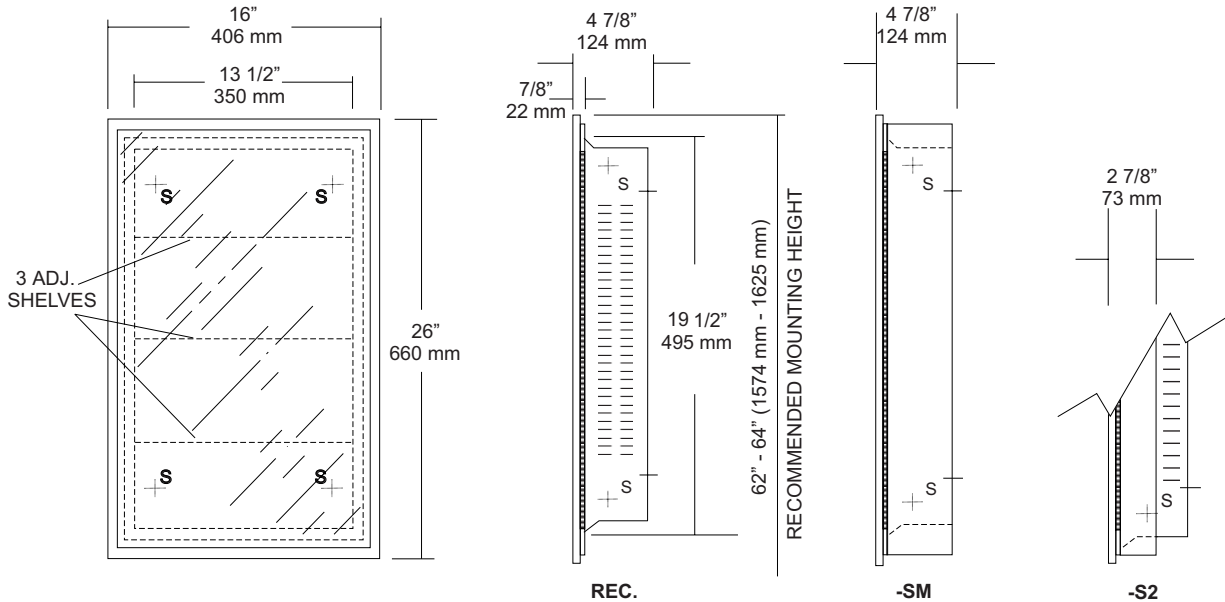

SPECIFICATIONS

Cabinet Body: Fabricated of #22 ga stainless steel formed for rigidity. Embossed louvers in body allow shelving to be adjustable. Flange surrounds cabinet body that has 1/4" returns to wall. (No miters or welds)

Cabinet Back: Stainless steel secured to cabinet body with multiple welds to cabinet body.

Mirror Door: 1/4" thick float plate glass, silver coated and sealed with a uniform coating of electrolytic copper plating. Mirror is guaranteed against silver spoilage for a period of 15 years. Non-absorbent filler behind mirror acts as a shock absorber.

Channel Frame: #22 ga stainless steel #4 satin finish.

Adjustable Shelving: Three (3) #22 ga stainless steel with #4 satin

Catch: Heavy duty magnetic catch.

Hinges: Full length, heavy duty stainless steel piano type

Collars: #22 ga stainless steel with #4 satin, one piece construction, finished to match cabinet body.

Overall Size: 16"W x 26"H x 4 7/8"D
406mm x 660mm x 124mm

Wall Opening: 14"W x 20"H x 4"D
355mm x 508mm x 102mm

U720-1626-S2: 2" semi-recessed collar, 2" wall opening

U720-1626-SM: Full surface mounted collar

INSTALLATION

Coordinate installation with architect and contractor. Provide a wall opening 14"W x 20"H. Depth will depend on style mounting. Insert cabinet into opening making sure cabinet is level and door will remain open until you manually close it. Secure cabinet with proper fasteners per application. Unit can be mounted to have a right hand or left hand swing door. Collars can be added in the field to accommodate semi-recessing or full surface mounting.

To comply with ADA code, one usable shelf must be mounted no higher than 44" above finished floor. (4.2.4)

NOTES

Formerly Model #: U721-1626

JOB #:

ITEM #:

QUANTITY:

MOUNTING	HANDING	TYPE	SIZE	OTHER

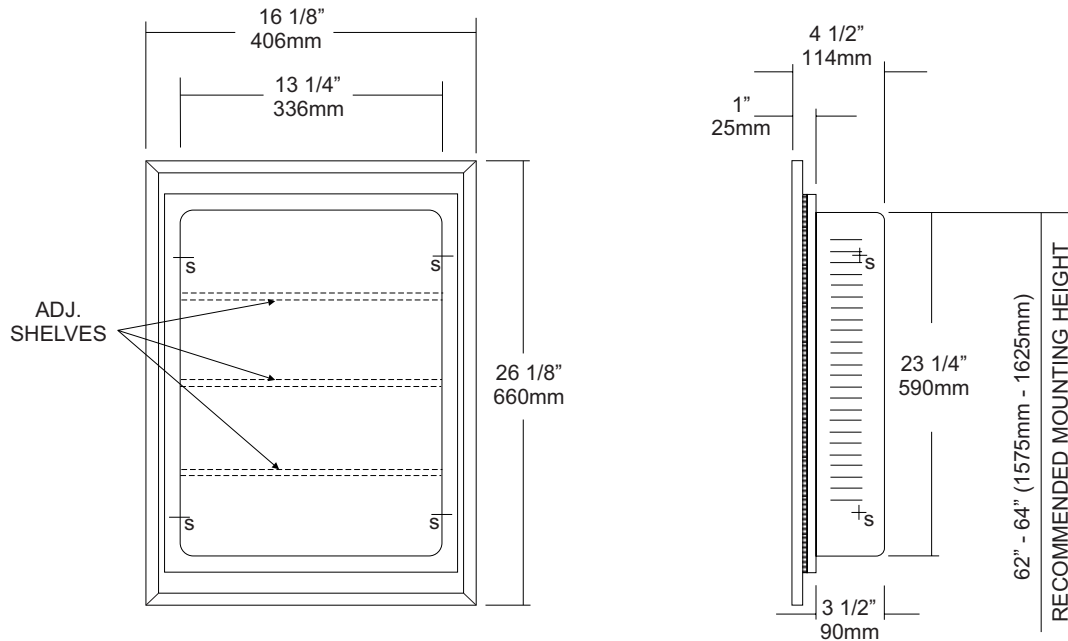

SPECIFICATIONS

- Body:** Fabricated of one piece deep drawn steel construction, oven baked enamel finish. Integral louvers to accommodate adjustable shelves.
- Mirror Door:** Float plate glass, silver coated and sealed electrolytic cooper plating. Door is secured by means of a magnetic catch.
- Frame:** Bright stainless steel finish.
- Hinges:** Heavy duty piano type hinges.
- Shelving:** Steel construction to match cabinet body with all edges deburred to prevent injury.
- Overall Size:** 16"W x 26"H x 4 5/8"D
406mm x 660mm x 114mm
- Wall Opening:** 14"W x 24"H x 3 3/4"D
356mm x 610mm x 95mm
- Shelving:** 3 adjustable

INSTALLATION

Coordinate installation with architect and or contractor. Provide wall opening 14"W x 24"H x 3 3/4"D that will allow cabinet to swing left or right without interference. Place cabinet in wall opening and secure with proper fasteners per application. Place unit on wall surface and make sure unit is level. Transfer mounting points and drill pilot holes. Secure unit to surface using proper fasteners per application.

To meet ADA code, a usable shelf on cabinet cannot be any higher than 44" (1120mm) above the finished floor. (4.2.4)

NOTES



UG2-A

Grab Bars

Revised 03/11

JOB #:

ITEM #:

QUANTITY:

MOUNTING	HANDING	TYPE	SIZE	OTHER



SPECIFICATIONS & INSTALLATION

Tubing: Fabricated of #18 ga stainless steel with a #4 satin finish. Available in 1 1/4" outside diameter. All bends are formed by an automatic mandrel bending process. All bars maintain a constant 1 1/2" offset.

Finish: Standard finish is a #4 satin finish. For a non-slip finish (peened) add suffix X to model number. (Ex. UG2X-A)

Flanges: Snap flanges are fabricated of 3" diameter, 3/8" deep drawn #22 ga stainless steel with #4 satin finish to match tubing. Flanges have dimples that secure over mounting plate.

Strength: Bars with a 1 1/2" offset clearance will support loads in excess of 900lbs when properly installed. Bars with greater offsets will support loads up to 250lbs when properly installed.

Installation: Before installing grab bars, verify with all state and local codes for requirements on bar diameter and type finish. Recommended mounting heights for grab bars are 33" - 36" centerline above finished floor. All mounting of grab bars when possible should have in wall mounting back plates. Find centerline mounting points and place bar on line making sure to be on center. Transfer mounting points (3 per flange) to wall. Drill pilot holes and secure bar with proper anchors per application. Snap cover over mounting plate.

Standard Lengths (Other sizes available upon request): 12", 16", 18", 24", 30", 32", 36", 42", 48", 50", 52", 54", 56"

FLANGE INFORMATION

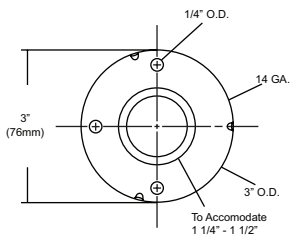

NOTES

UX131-BF Series Square Towel Bar

Revision 03/11

JOB #:

ITEM #:

QUANTITY:

MOUNTING	HANDING	TYPE	SIZE	OTHER

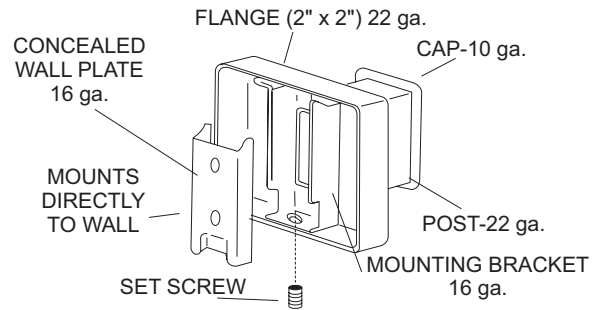
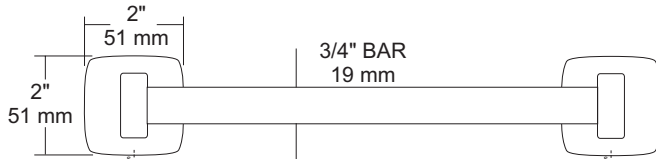
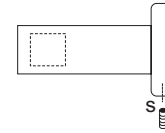
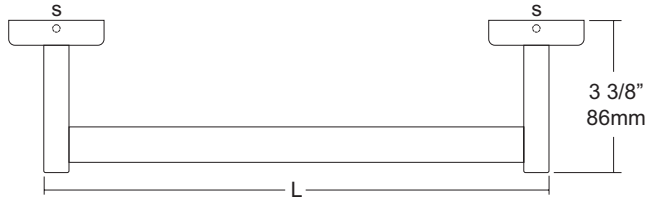

SPECIFICATIONS

UX Accessories: All UX bath accessories series are fabricated of stainless steel with a bright or satin finish. Mounting plates are concealed with a snap-on type plate secured by a set screw.

Flange: 2" x 2" flange #22 ga stainless steel.

Post: #22 ga stainless steel.

Bar: #22 ga stainless steel, 3/4" dia

Mounting Plate: #16 ga concealed wall plate. Set screw secures mounting plate and flange.

Standard Lengths: 18", 24", 30", 36" (475mm, 610mm, 762mm, 914mm)

Overall Size: 2"H x 3 3/8"D (51mm x 86mm)

UX131-SF: Same as UX131-BF with satin finish.

INSTALLATION

Provide an area on wall surface at desired or specified location. The centerline distance between the mounting plates is 1/2" less than the length of the towel bar. Place concealed mounting plate on wall surface and transfer mounting plate on wall surface and transfer mounting points. Drill pilot holes and secure with proper fasteners. Place snap-on flange over plate and secure with set screw. Repeat same step for second post. Place towel bar in post and place cover over plate to make sure spread is correct. Secure cover if bar fits.

NOTES

MOUNTING	HANDING	TYPE	SIZE	OTHER

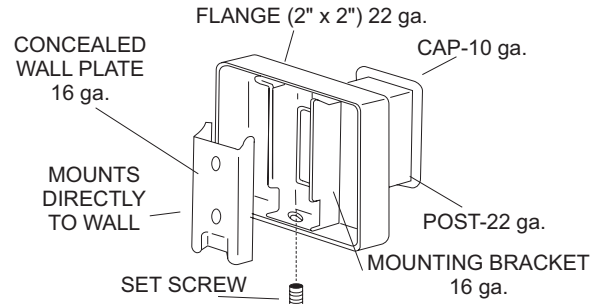
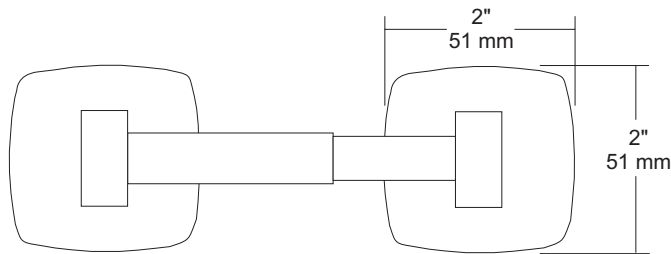
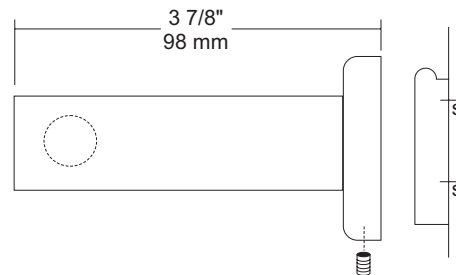
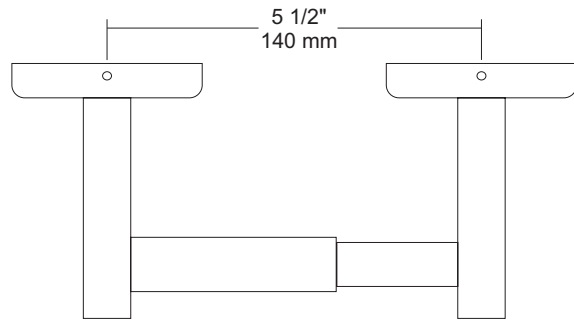

SPECIFICATIONS

UX Accessories: All UX bath accessories series are fabricated of stainless steel with a bright or satin finish. Mounting plates are concealed with a snap-on type plate secured by a set screw.

Flange: 2" x 2" flange #22 ga stainless steel.

Post: #22 ga stainless steel.

Mounting Plate: #16 ga concealed wall plate. Set screw secures mounting plate and flange.

Spindle: Spring loaded, chrome plated plastic.

Optional U007 Theft Resistant Adapter: Prevents spindle from being removed until roll has been depleted.

Overall Size: 7 1/2" W x 2"H x 1 5/8"D

51mm x 51mm x 43mm

UX141-SF: Same as UX141-BF with satin finish

INSTALLATION

Provide an area on wall surface at desired or specified location. Place concealed mounting plate on wall surface and transfer mounting points. Drill pilot holes and secure with proper fasteners. Place snap-on flange over plate and secure with set screw. Centerline space between posts is aprx. 5 1/2"W. Repeat same steps for other post. Place a roll of tissue on spindle and place in posts before securing the covers down securely. If roll spins freely, secure post with set screw. All toilet tissue dispensers must have a non-control delivery to meet ADA code. (4.16)

NOTES