

JOB #:

ITEM #:

QUANTITY:

MOUNTING	HANDING	TYPE	SIZE	OTHER

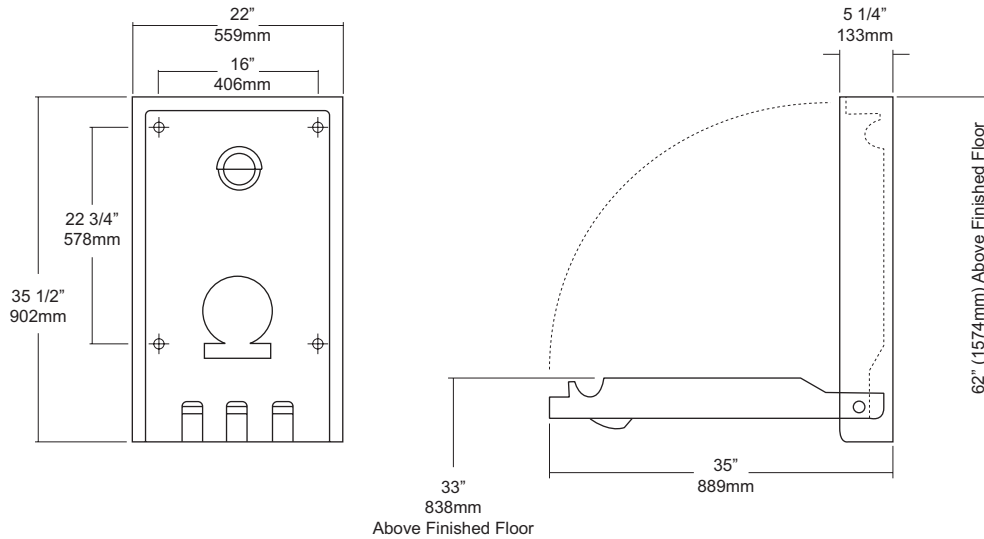

SPECIFICATIONS

Body: Fabricated of high impact ABS polyethylene with radius leading edges that prevent injury. Embedded Microban antimicrobial is odor resistant and easy to clean. Base is concave formed to allow safe and easy changing. Molded graphics and brail to comply with ADA.

Liner Dispenser: An integral part of body that is standard with each unit.

Pneumatic Cylinder: Concealed pneumatic cylinder & hinge structure provides controlled and smooth open and close motion.

Safety Straps: Snap lock fasteners to hold child securely in place.

Overall Size: 22"W x 35 1/2"H x 5 1/4"D (closed) 35"D (open)
559mm x 902mm x 133mm (closed) 889mm (open)

Colors Available: Cream, Grey

INSTALLATION

Coordinate installation with architect or contractor to avoid interference with surrounding objects. Hold unit up to wall and open to verify there are no obstructions to interfere with operation of station. Transfer mounting point locations to wall surface and drill pilot holes. Secure unit with proper fasteners for each application. (Recommend a qualified carpenter to install unit) Unit can be lowered with one hand and into position with less than 5 lbs of force, wall openingut turning or twisting of wrist. Verify with local codes and type approach (forward or side) for proper mounting height above finished floor.

Unit should be cleaned once or more daily with a clean nylon brush and spray disinfectant.

When properly installed, baby changing stations comply with ASTM static load performance requirements.

NOTES

Formerly Model #: U945V