



Date

Project Name

Attn

From

Phone

Fax

Email arch@cmctech.kr

WASHROOM PARTITIONS | WASHROOM ACCESSORIES | STORAGE SYSTEMS | VISUAL DISPLAY PRODUCTS

509 TEMPLE HILL RD. NEW WINDSOR NY 12553 P. 845.562.3332 F. 845.562.3391 AJW.COM



U925

Retractable Shower Seat

Revision 1/14

JOB #:

ITEM #:

QUANTITY:

MOUNTING	HANDING	TYPE	SIZE	OTHER

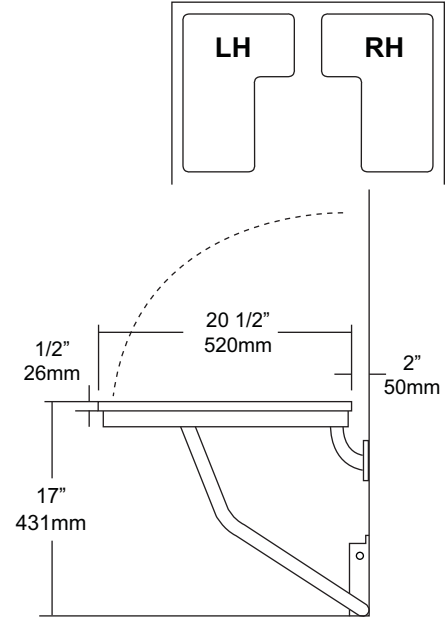
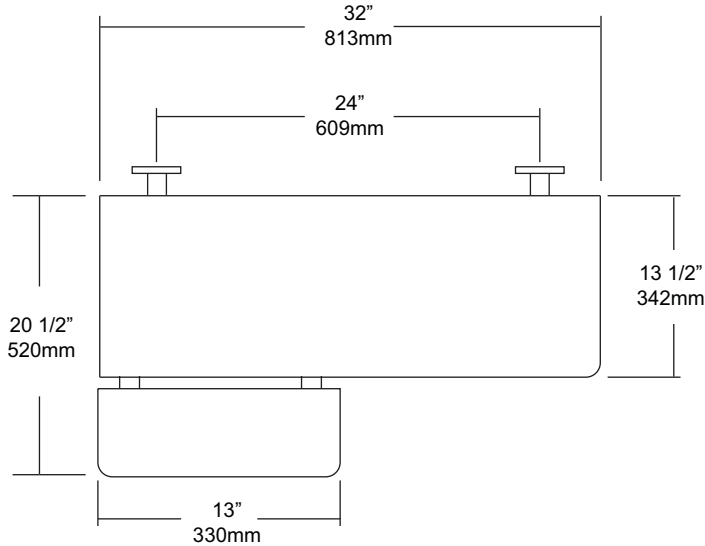

SPECIFICATIONS

Seat: Fabricated of #18 gauge #4 satin finish stainless steel welded to frame. All leading edges on slats have a radius edge for safety. Handing is required for this seat.

Tubing: Fabricated of #18 gauge stainless steel with a #4 satin finish.

Main Frame: 1 1/4" square tubing with capped ends. Underside has no exposed fasteners.

Flanges: Fabricated of #18 gauge stainless steel with four (4) exposed mounting points. Under slung supports have a 1 1/4"OD.

Leg Support: Fabricated of #18 gauge stainless steel one piece construction.

Mounting Bracket: #16 gauge stainless steel "hat" style bracket with four (4) mounting points. Bracket acts as a guide to raise and lower platform. For maximum support bracket should be mounted on finished floor to accept load transfer. Seat will remain in an upright position when not in use by means of a spring clip.

Overall Size: 32"W x 20 1/2"D (Seating Area) 813mm x 527mm

Handing:

U925-R: Right Handed

U925-L: Left Handed

INSTALLATION

To comply with ADA code, seat should be mounted at a height where the seating location should be at a height of 17" - 19" above finished floor. Check all State and Local code for building requirements. Recommend in wall mounting on all shower seats (BP10) for maximum strength. Place seat up against wall surface making sure seat is at the proper mounting height level. Transfer all mounting point locations and drill pilot holes. Secure seat with proper fasteners for each application. (Fasteners not provided, must be ordered separate) Snugly secure seat and check seat to be level and the raising and lowering of the seat does not bind. When all checks good, finish securing fasteners. When properly mounted seat will support over 500 lbs. To conform with ADA code 4.21.3 and 4.26.3

Note: This shower seat is not intended to be installed in applications that have shower bases with rounded corners. AJW recommends the U928 for such applications.

NOTES

Formerly Model #: U925-SS