



Date 05/06/2015  
Project Name Preston ES / MS  
Attn Lee Totty  
From John Olszewski  
Phone (724)693-2666  
Fax (724)693-8766  
Email john@olszewskisales.com

WASHROOM PARTITIONS | WASHROOM ACCESSORIES | STORAGE SYSTEMS | VISUAL DISPLAY PRODUCTS

---

509 TEMPLE HILL RD. NEW WINDSOR NY 12553 P. 845.562.3332 F. 845.562.3391 AJW.COM



**U775 Series**  
Surface Mounted Shelf

Revision 07/11

JOB #:

ITEM #:

QUANTITY:

MOUNTING	HANDING	TYPE	SIZE	OTHER

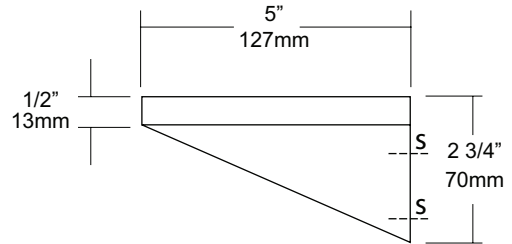
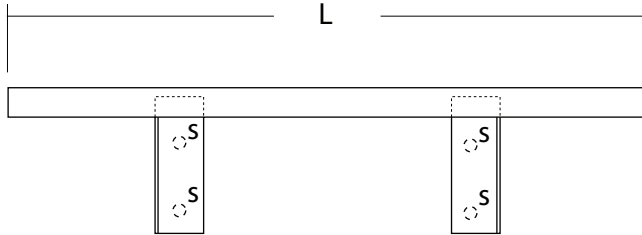

<b>SPECIFICATIONS</b>	<b>INSTALLATION</b>
-----------------------	---------------------

**Shelves:** Fabricated of #18 ga stainless steel. All edges are turned down 1/2" with front edges turned down & back 1/2" for maximum strength and rigidity. All corners are deburred and polished smooth for safety.

**Brackets:** Fabricated of #16 ga stainless steel permanently welded to shelf with exposed mounting points. Brackets are spaced maximum 30" centerline.

**Surface mounted shelf 5"D (127mm)**

Provide an area on wall surface at desired or specified location. Place unit up to wall making sure unit is level. Transfer mounting points to surface and drill pilot holes. Secure shelf to surface with proper fasteners per each application.

**NOTES**



**U778 Series**  
Surface Mounted Shelf

Revision 07/11

JOB #:

ITEM #:

QUANTITY:

MOUNTING	HANDING	TYPE	SIZE	OTHER

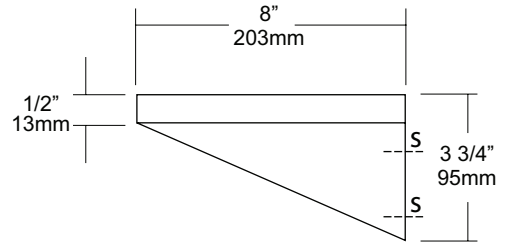
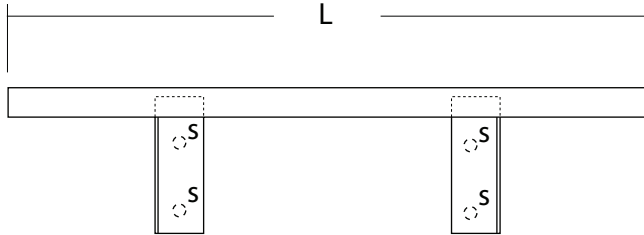

**SPECIFICATIONS**

**Shelves:** Fabricated of #18 ga stainless steel. All edges are turned down 1/2" with front edges turned down & back 1/2" for maximum strength and rigidity. All corners are deburred and polished smooth for safety.

**Brackets:** Fabricated of #16 ga stainless steel permanently welded to shelf with exposed mounting points. Brackets are spaced maximum 30" centerline.

**Surface mounted shelf 8"D. (203mm)**

**INSTALLATION**

Provide an area on wall surface at desired or specified location. Place unit up to wall making sure unit is level. Transfer mounting points to surface and drill pilot holes. Secure shelf to surface with proper fasteners per each application.

**NOTES**



# U929

## Retractable Shower Seat

Revision 1/14

JOB #:

ITEM #:

QUANTITY:

MOUNTING	HANDING	TYPE	SIZE	OTHER

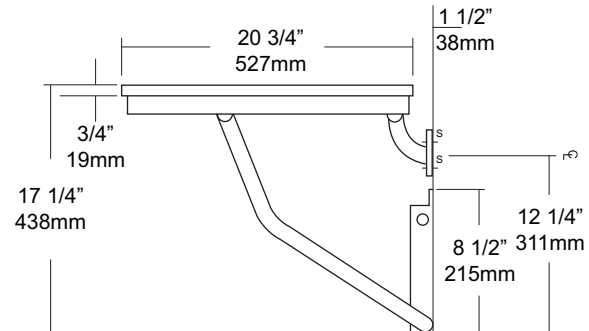
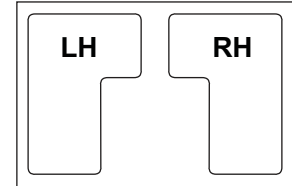
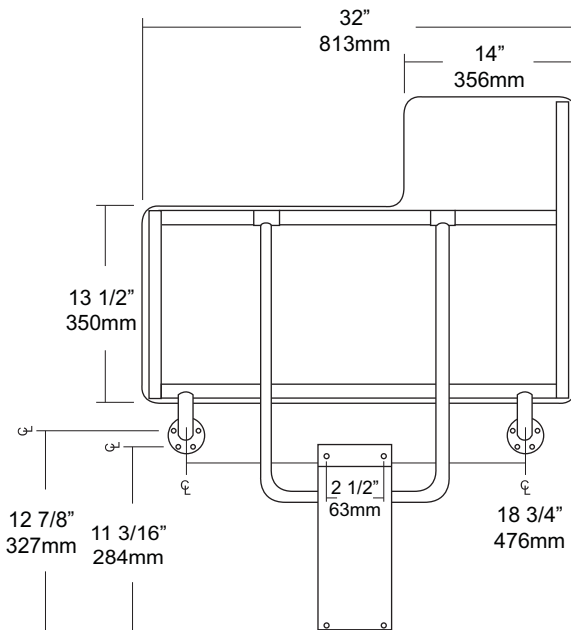

### SPECIFICATIONS

**Seat:** Fabricated of 3/4" thick, one piece polymers (white) with all leading edges having a radius to prevent injury. Seat is secured to frame with carriage bolts and acorn nuts. Seat is reversible and handing is not required

**Tubing:** Fabricated of #18 ga stainless steel with #4 satin finish.

**Main Frame:** 1 1/4" diameter square tubing with capped ends.

**Flanges:** #18 gauge stainless steel with exposed mounting points. Under slung supports have a 1 1/4" OD

**Supports:** #18 ga stainless steel 1 1/4" dia diagonal stainless steel support guides for raising and lowering of seat.

**Mounting Bracket:** #18 gauge stainless steel "hat" style bracket with four (4) mounting points. Bracket acts as a guide for raising and lowering of seat. For maximum support, bracket is mounted resting on floor absorbing load transfer. Seat will remain in an upright position when not in use by means of a spring clip. Seat has been tested to maintain a 500 lb static load.

**Overall Size:** 32"W x 20 3/4"D (seating area)  
813mm x 514mm

**\*Wall to floor mounting design provides equal distribution of weight to ensure safe operation.**

### INSTALLATION

To comply with ADA Code, seat should be mounted at a height between 17" - 19" above finished floor. Check all state and local codes for building requirements.. Recommend in wall mounting on all shower seats. (BP10) Place seat up against wall making sure the extended part of seat has an offset no more than 1 1/2" away from wall. (Same as grab bar) Transfer mounting points to wall surface and drill pilot holes. Secure seat to surface with proper fasteners for each application. Snugly secure seat to surface and check seat to be level. If seat is level raise and lower seat to check path of travel. Finish securing seat after checking seat for proper operation. When properly mounted seat will support up to 500 lbs and will conform with ADA Code 4.21.3 and 4.26.3. To change handing, remove carriage bolts, switch square length tubing to opposite side and flip deck to change handing and secure with carriage bolts to framing.

Note: This shower seat is not intended to be installed in applications that have shower bases with rounded corners. AJW recommends the U928 for such applications.

### NOTES



# U944

## Baby Changing Station

Revision 11/14

JOB #:

ITEM #:

QUANTITY:

MOUNTING	HANDING	TYPE	SIZE	OTHER

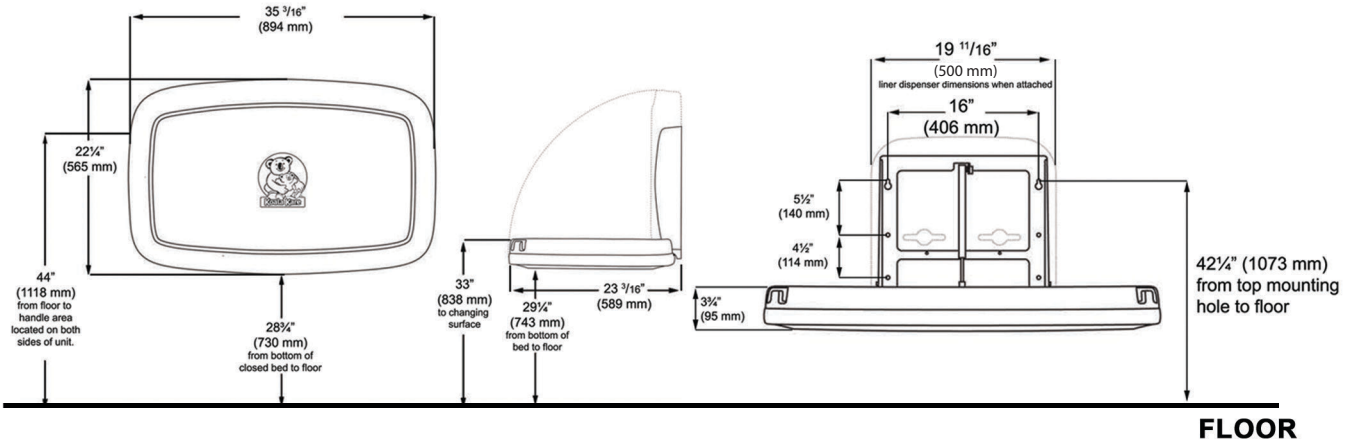

**FLOOR**

### SPECIFICATIONS      INSTALLATION

**Body:** FDA approved injection molded polypropylene with Microban antimicrobial additive. Reinforced steel-on-steel hinge mechanism and metal mounting chassis. Labeled usage instructions and safety messages in four languages.

**Liner Dispenser:** An integral part of body that is standard with each unit. (Capacity: 50)

**Pneumatic Cylinder:** Concealed pneumatic cylinder & hinge structure provides controlled and smooth open and close motion.

**Safety Straps:** Nylon safety strap snap lock fastens to hold child securely in place.

**Overall Size:** 35 3/16"W x 22 1/4"H x 4"D (closed) 23 3/16"D (open)

**894mm x 565mm x 102mm (closed), 589mm (open)**

**Available Colors:** Cream & Grey

**Optional Braille Label (Not included)**

Coordinate installation with architect or contractor to avoid interference with surrounding objects. Hold unit up to wall and open to verify there are no obstructions to interfere with operation of station. From finished floor to the top of the unit closed should be at a height of 48". Transfer mounting point locations to wall surface and drill pilot holes. Secure unit with proper fasteners for each application. (Recommend a qualified carpenter to install unit) Unit can be lowered with one hand and into position with less than 5 lbs of force, wall opening turning or twisting of wrist. Verify with local codes and type approach (forward or side) for proper mounting height above finished floor. Unit can support up to 200lbs when properly installed.

Unit should be cleaned once or more daily with a clean nylon brush and spray disinfectant.

When properly installed, baby changing stations comply with ASTM static load performance requirements.

### NOTES

Formerly Model #: U945H



# UJ13 Series

## Mop Holder Strip & Shelf Combination Unit

Revision 03/11

JOB #:

ITEM #:

QUANTITY:

MOUNTING	HANDING	TYPE	SIZE	OTHER

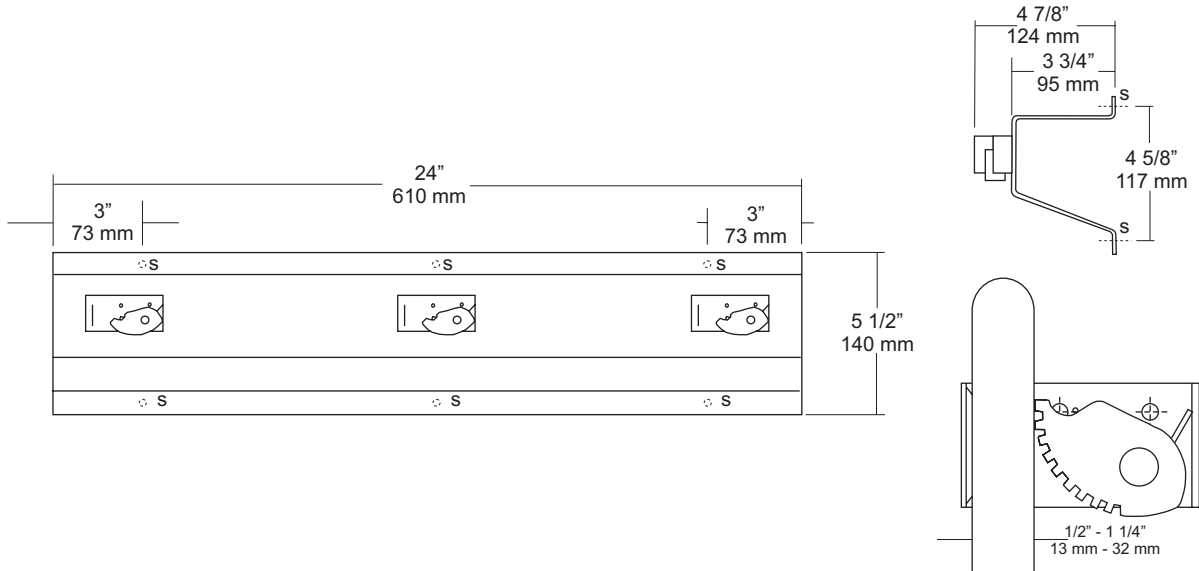

### SPECIFICATIONS

**Mop Strip & Shelf:** Fabricated of #18 ga stainless steel with a #4 satin finish. Upper portion of strip is formed in the shape of a "hat" channel, that is utilized as a shelf, projects 3 3/4" from wall surface. Lower portion is angled to add rigidity and strength to strip.

**Mop Holders:** UJ19 plated reinforced steel with serrated cam type hard rubber mop or broom holder. Holds handles 1/2" to 1 1/4" diameter.

**Verify Style:**

**UJ13A:** 24"L (610mm) with 3 holders.

**UJ13B:** 36"L (914mm) with 4 holders.

**UJ13C:** 48"L (1219mm) with 5 holders.

**UJ13D:** 60"L (1524mm) with 6 holders.

### INSTALLATION

Place unit to wall surface making sure unit is level and transfer mounting points. Drill pilot holes and secure unit with proper fasteners per application.

### NOTES



# UJ14 Series

Hook Strip

Revision 03/11

JOB #:

ITEM #:

QUANTITY:

MOUNTING	HANDING	TYPE	SIZE	OTHER

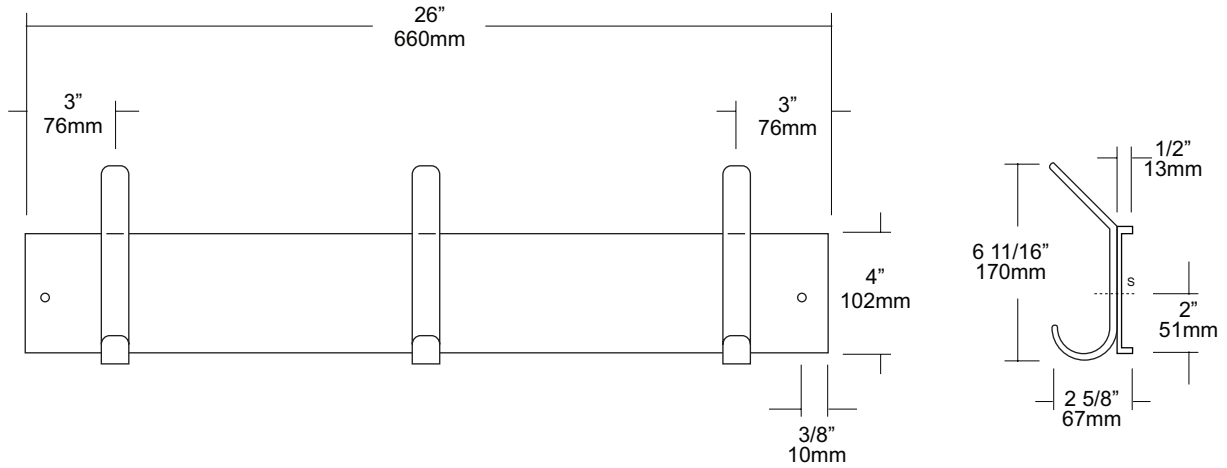

### SPECIFICATIONS

**Hook Strip:** Fabricated of #20 ga stainless steel with a #4 satin finish. Ends of strip are returned 1/2" to wall surface.

**Hooks:** Fabricated of #14 gauge stainless steel finished to match strip. Leading edges of hooks are radiused to prevent injury and extends 2 5/8" from strip surface.

**Verify Style:**

- UJ14A:** 26"L (660mm) with 3 hooks.
- UJ14B:** 36"L (914mm) with 4 hooks.
- UJ14C:** 46"L (1168mm) with 5 hooks.
- UJ14D:** 56"L (1422mm) with 6 hooks.

### INSTALLATION

Place unit to wall surface making sure unit is level and transfer mounting points. Drill pilot holes and secure unit with proper fasteners per application.

### NOTES



# UJ41 Series

## Mop Holder & Hook Strip Combination Unit

Revision 03/11

JOB #:

ITEM #:

QUANTITY:

MOUNTING	HANDING	TYPE	SIZE	OTHER

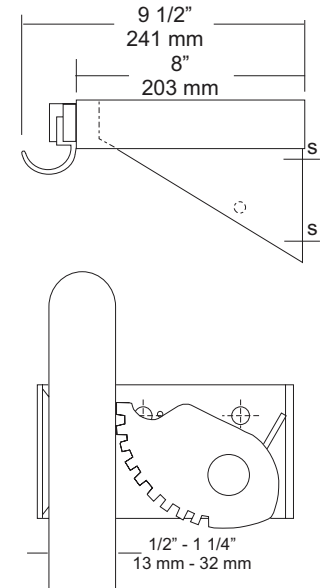
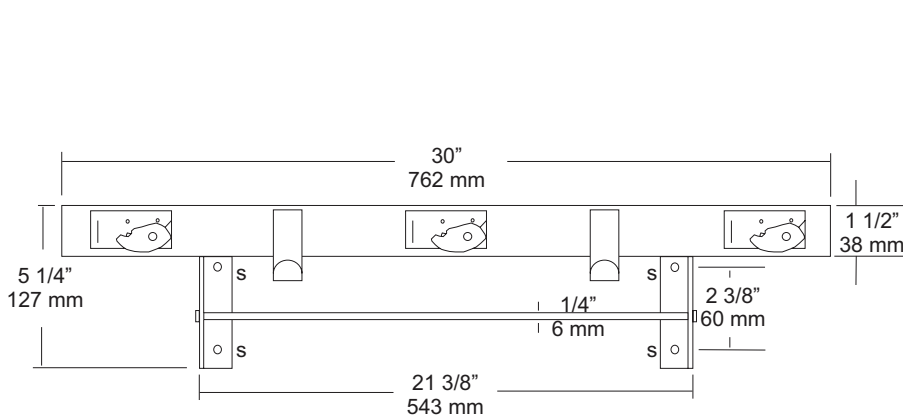

### SPECIFICATIONS

- Shelf:** Fabricated of #18 ga stainless steel with a #4 satin finish, 8" deep (203mm) bent down 1 1/2" with 1/2" returns back for rigidity and safety.
- Mop Holders:** UJ19 plated reinforced steel with serrated cam type hard rubber mop or broom holder. Holds handles 1/2" to 1 1/4" diameter.
- Rag Hooks:** Fabricated of #18 ga stainless steel with a #4 satin finish.
- Mounting Brackets:** #16 ga stainless steel with exposed mounting points.
- Drying Rod:** 1/4" diameter stainless steel rod, secured to outside of support/mounting brackets with locking caps.
- Verify Style:**
- UJ41A:** 30"L (762mm) with 3 holders, 2 hooks.
- Rod Length:** 21 3/8" (565mm)
- UJ41B:** 36"L (914mm) with 4 holders, 3 hooks.
- Rod Length:** 27 3/8" (692mm)
- UJ41C:** 42"L (1066mm) with 5 holders, 4 hooks.
- Rod Length:** 33 3/8" (845mm)
- UJ41D:** 48"L (1219mm) with 6 holders, 5 hooks.
- Rod Length:** 39 3/8" (997mm)

### INSTALLATION

Place unit to wall surface making sure unit is level and transfer mounting points. Drill pilot holes and secure unit with proper fasteners per application.

### NOTES





# UX110-BF

Single Robe Hook

Revision 03/11

JOB #:

ITEM #:

QUANTITY:

MOUNTING	HANDING	TYPE	SIZE	OTHER

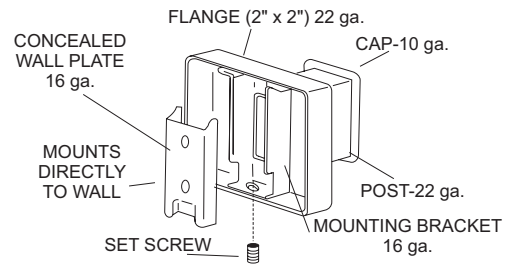
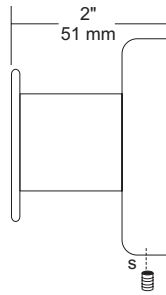
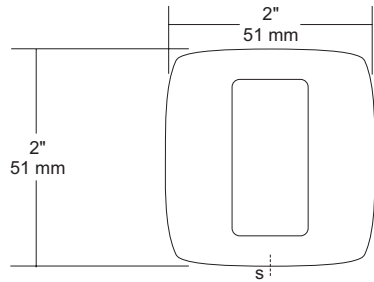

### SPECIFICATIONS

**UX Accessories:** All UX bath accessories series are fabricated of stainless steel with a bright or satin finish. Mounting plates are concealed with a snap-on type plate secured by a set screw.

**Hook:** #10 ga stainless steel hook.

**Flange:** 2" x 2" flange #22 ga stainless steel.

**Post:** #22 ga stainless steel.

**Mounting Plate:** #16 ga concealed wall plate. Set screw secures mounting plate and flange.

**Overall Size:** 2"W x 2"H x 1 5/8"D

**51mm x 51mm x 41mm**

**UX110-SF:** Same as UX110-BF with satin finish

### INSTALLATION

Provide an area on wall surface at desired or specified location. Place concealed mounting plate on wall surface and transfer mounting points. Drill pilot holes and secure with proper fasteners. Place snap on flange over plate and secure with set screw.

### NOTES