



Date

Project Name

RC-CAMP

Attn

Eng, Nebal

From

Silkroad co.

Phone

(050)688-5992

Fax

Email

silkroad.ksa@gmail.com

WASHROOM PARTITIONS | WASHROOM ACCESSORIES | STORAGE SYSTEMS | VISUAL DISPLAY PRODUCTS

509 TEMPLE HILL RD. NEW WINDSOR NY 12553 P. 845.562.3332 F. 845.562.3391 AJW.COM

JOB #:

ITEM #:

QUANTITY:

MOUNTING	HANDING	TYPE	SIZE	OTHER
----------	---------	------	------	-------

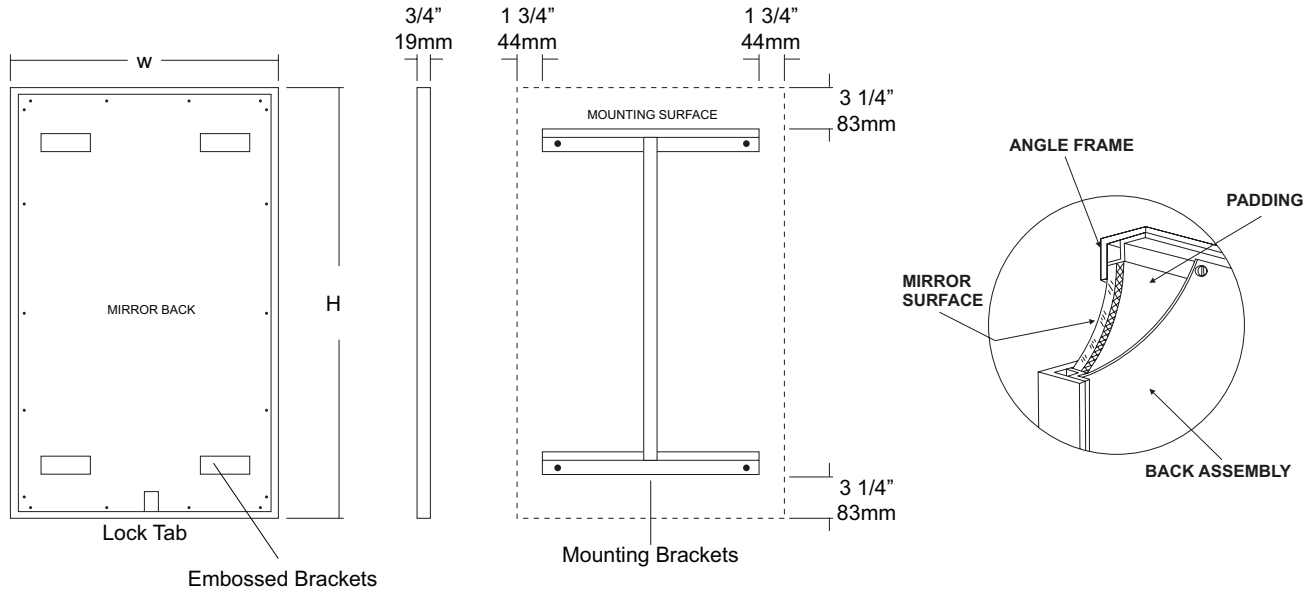

SPECIFICATIONS

Frame: Fabricated of #18 ga stainless steel, #4 satin finish. 3/4" x 3/4" frame with welded mitered corners are ground and polished smooth. #22 ga concealed "Z" channel is spot welded to inner perimeter of frame for reinforcement and greater rigidity.

Mirror: 1/4" thick type 1 transparent flat type, class 1 - clear glass mirrors. Mirror is coated with silver and sealed with a uniform electrolytic copper plating, along with two coats of paint for added protection. Mirrors are guaranteed against silver spoilage for a period of 15 years. Mirrors conform to ASTM C1036 and ASTM C1503-R8.

Filler: 3/16" thick full size, shock absorbing, water resistant, non-abrasive polyethylene padding protects all concealed mirror surfaces.

Back: #20 ga pre-plated galvanized steel, with embossed horizontal louver mounting brackets. Embossed theft resistant pressure activated clip lock device, locks mirror in place to wall hangers. Back is secured to frame with concealed Phillips head screws.

Hangers: Fabricated of #20 ga pre-plated steel galvanized steel with mounting points.

Standard Sizes Available (W x H): 16"x24", 16"x20", 16"x30", 18"x24", 18"x30", 18"x36", 20"x60", 24"x30", 24"x36", 24"x42", 24"x48", 24"x60", 24"x72", 18"x60", 24"x60", 18"x72"

Mirrors conform to Federal Specifications DD-M-00411b & DDg- 541D.

Options:

VC: Safety Glass(Vinyl clad)

T: Tempered Glass

LG: Laminated Glass

PM: Plastic Acrylic

8B: #8 Reflective s/s

LX: Polycarbonate

Recommended max size-8B mirrors: 72" x 47 1/2"

Mirrors are always ordered Width x Height

Framed mirrors are fabricated to a tolerance of +/- 1/8".

INSTALLATION

Coordinate installation with architect / contractor for specific mounting location and height for each mirror application. Making sure "I" bracket is level, transfer all mounting point locations to wall surface from drawing. Secure brackets with proper fasteners for each application. Slide mirror down over horizontal brackets until clip lock secures mirror in place. Mirror can only be removed by inserting tool through hole at bottom of frame depressing clip. This will allow mirror to slide up over brackets. Fillers are available if mirrors are mounted above and below tile line. (U004 Filler) filler material will match mirror frame to form a one piece construction.

To meet ADA Code, bottom edge of reflective surface can be no higher than 40" above finished floor. (4.19.6) Full length mirrors may be used for universal application when installed in correct locations.

Abrasive cleaners & chloric solutions should not be used on mirrors. Discoloring and /or scratching of frame and reflective surface may occur.

NOTES

JOB #:

ITEM #:

QUANTITY:

MOUNTING	HANDING	TYPE	SIZE	OTHER

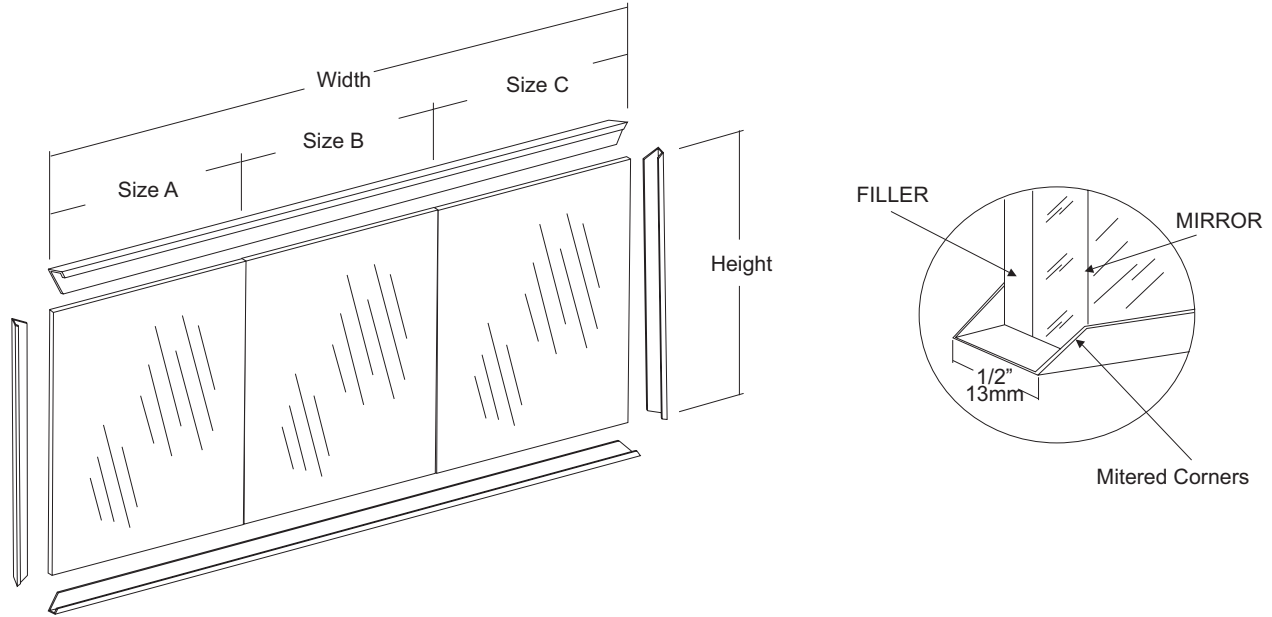

SPECIFICATIONS

Mirror: 1/4" thick type 1 transparent flat type, class 1 - clear glass mirrors. Mirror is coated with silver and sealed with a uniform electrolytic copper plating, along with two coats of paint for added protection. Mirrors are guaranteed against silver spoilage for a period of 15 years. Mirrors conform to ASTM C1036 and ASTM C1503-R8.

Frame: #18 ga stainless steel with a #4 satin finish. (1/2" x 1/2" x 1 3/4" channel)

Backing: 1/4" thick tempered Masonite backing strips.

Optional Surfaces & Sizes:

- PM: Plastic Mirrors (96" x 48" max size for 1 piece of glass)
- PG: Plate Glass (Floor) (96" x 48" max size for 1 piece of glass)
- LG: Laminated Glass (96" x 48" max size for 1 piece of glass)
- T: Tempered Mirror (96" x 48" max size for 1 piece of glass)
- VC: Vinyl Clad (96" x 48" for 1 piece of glass)

When mirrors are fabricated with multiple pieces of glass, size of each piece must be specified.

Mirrors are always ordered Width x Height

Fabricated to a tolerance of ± 1/8"

INSTALLATION

Mount the bottom channel at desired or specified location. Place a level across the channel to make sure mirror will be level. Place glass and Masonite strips (vertical) in channel and check with level again. Clips are required on the top for securing mirror properly. (SCL-J: stainless steel clips). Measure from the bottom "J" mold up height of mirror and strike a line. Mount top "J" the same way allowing 3/4" to lock glass in place. Place glass and Masonite in channel and slide top "J" down to lock in place. Follow the same instructions for top and bottom style and add the two side "J" channel.

The bottom reflective surface edge must be mounted 40" above finished floor to comply with ADA code, 4.19.6.

NOTES