

JOB #:

ITEM #:

QUANTITY:

MOUNTING	HANDING	TYPE	SIZE	OTHER

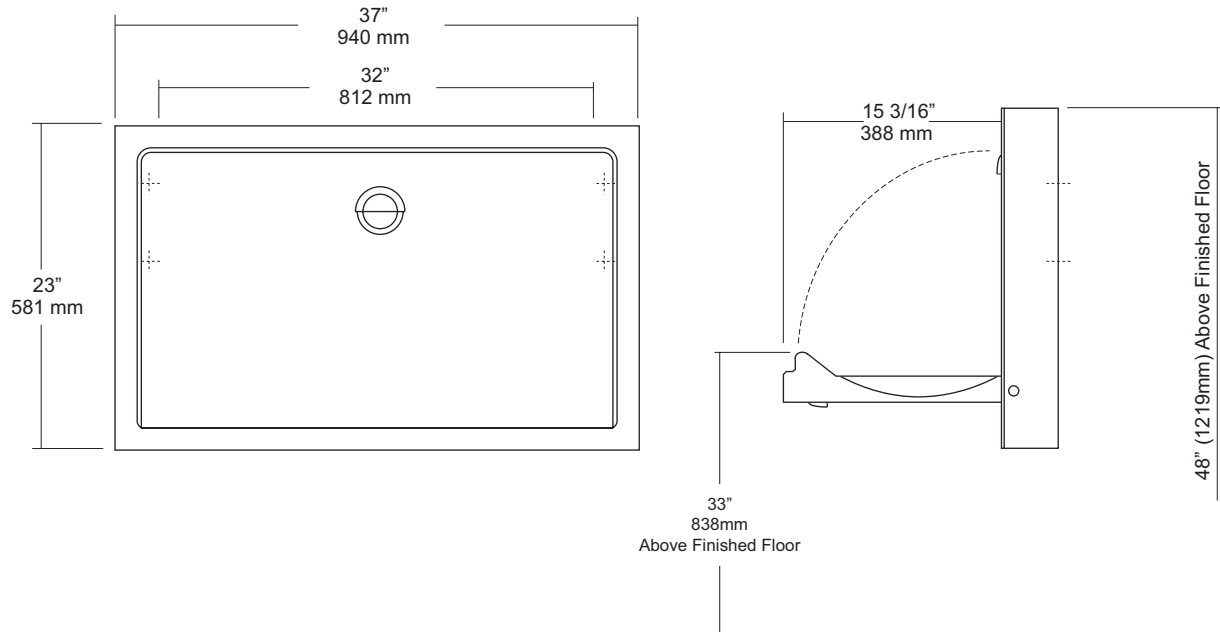

SPECIFICATIONS

Body: Fabricated of high impact ABS polyethylene with radius leading edges that prevent injury. Material is odor resistant and easy to clean and available in cream or grey. Base is concave formed to allow safe and easy changing. Molded graphics and brail comply with ADA code.

External Wrap: Fabricated of #18 ga stainless steel with a #4 satin finish. Wrap is reinforced with a full length steel on steel mechanism with #11 ga mounting plate.

Liner Dispenser: An integral part of body that is standard with each unit.

Gas Shocks: Concealed gas spring actuators ensure a safe and smooth open and close motion.

Safety Straps: Snap lock fasteners to hold child securely in place.

Overall Size: 37"W x 23"H x 4"D (closed)

939mm x 584mm x 101mm

Colors Available: Grey

INSTALLATION

Coordinate installation with architect or contractor to avoid interference with surrounding objects in and out of wall. Making sure unit is level, transfer mounting point locations. Drill pilot holes and secure with proper fasteners for each application. (Recommend a qualified carpenter to install unit) Unit can be lowered with one hand and into position with less than 5 lbs of force, wall opening turning or twisting of wrist. Verify with local codes and type approach (forward or side) for proper mounting height above finished floor. Mounting points are located on side of unit.

Unit should be cleaned once or more daily with a clean nylon brush and spray disinfectant.

When properly installed, baby changing stations comply with ASTM static load performance requirements.

NOTES

Formerly Model #: U945H-SS