



Date

Project Name

Attn

From

Phone

Fax

Email

WASHROOM PARTITIONS | WASHROOM ACCESSORIES | STORAGE SYSTEMS | VISUAL DISPLAY PRODUCTS

509 TEMPLE HILL RD. NEW WINDSOR NY 12553 P. 845.562.3332 F. 845.562.3391 AJW.COM

MOUNTING	HANDING	TYPE	SIZE	OTHER
----------	---------	------	------	-------

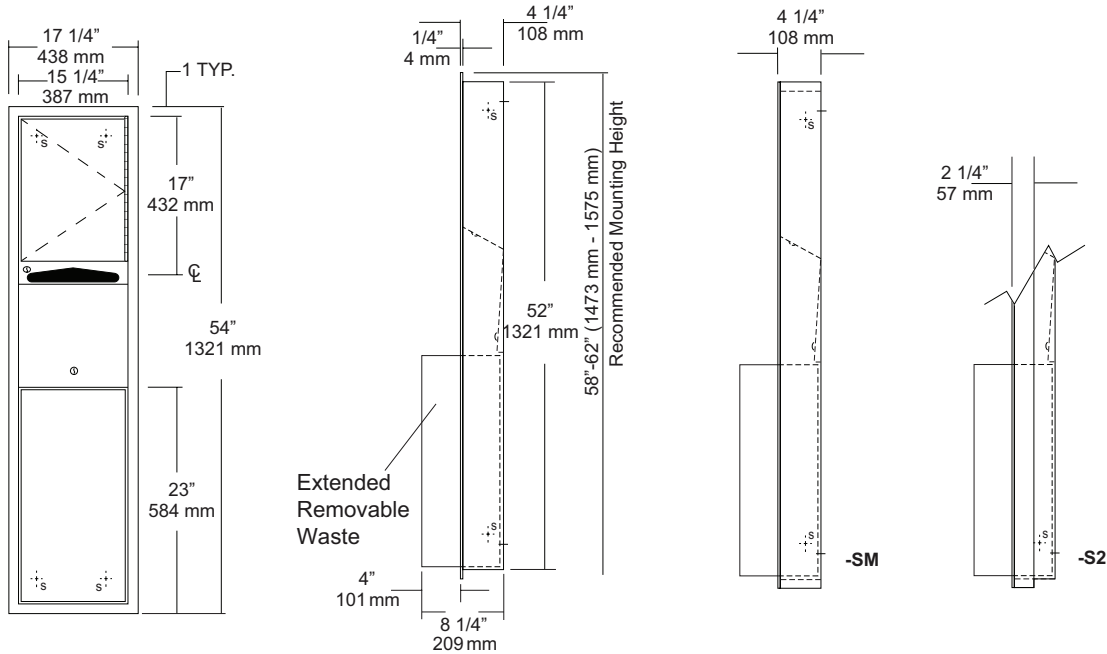

SPECIFICATIONS

Body: Fabricated of #22 ga stainless steel with a #4 satin finish.

Flange: Fabricated of #22 ga stainless steel finished to match cabinet with 1/4" returns. (No miters or welds)

Cabinet Back: Fabricated of stainless steel formed for rigidity with multiple welds to cabinet body.

Cabinet Door: Fabricated of #22 ga stainless steel with #4 satin finish.

Towel Dispenser: Fabricated of #22 ga stainless steel with hemmed edges to prevent injury and towel tearing.

Removable Waste: Fabricated of #22 ga stainless steel #4 satin finish with all leading edges to have a radius. Unit is secured in place by a bottom bracket guide and top lock.

Hinge: Full length, heavy duty, stainless steel piano type hinge.

Locks: Pin tumbler commercial quality, keyed like all other AJW cabinets.

Collars: Fabricated of #22 ga stainless steel, finished to match cabinet. (Used when full recessing cannot be accomplished)

Overall Size: 17 1/4"W x 54"H x 8 1/4"D (wall depth req)
438mm x 1372mm x 108mm

Wall Opening: 15 3/4"W x 52 1/2"H x 4"D
400mm x 1334mm

U650-S2: semi-recessed. with 2" collar, 2" wall opening 203mm

U650-SM: Full surface mounted collar.

Towel Capacity: 600 c-fold or 800 multifold

Waste Capacity: 12 gallons (1.6 cu ft)

Options :

-VL1: Vinyl Liner

INSTALLATION

Coordinate installation with architect and contractor to avoid interference with pipes, vents, etc. Provide a rough wall opening 15 3/4"W x 52 1/2"H. See chart for required wall depth. If collar is required, slide collar over the back before installing into wall. Remove waste from cabinet and mount unit plumb and true in opening with proper fasteners per application. Secure waste in cabinet and load paper towels.

When cleaning cabinet use a non abrasive non-chloric solution and wiped off with the grain of the cabinet.

NOTES

JOB #:

ITEM #:

QUANTITY:

MOUNTING	HANDING	TYPE	SIZE	OTHER

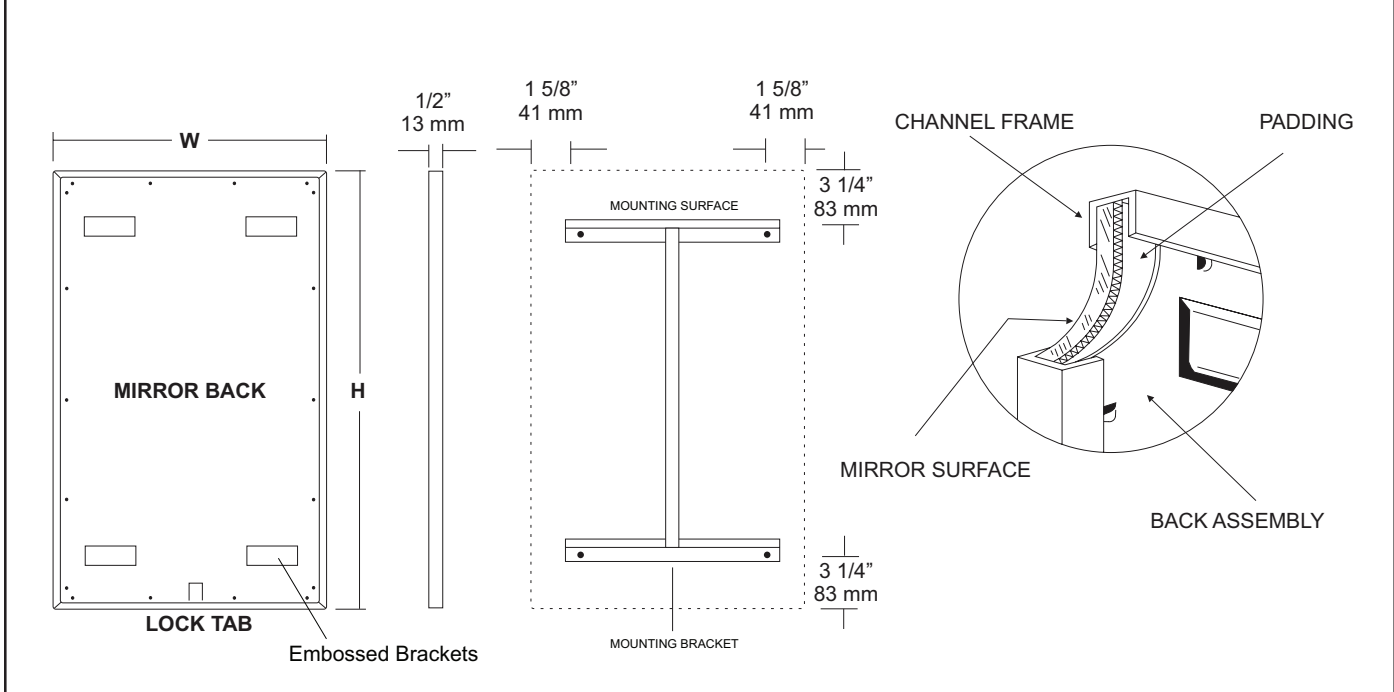

SPECIFICATIONS	INSTALLATION
----------------	--------------

Frame: Fabricated of #20 ga stainless steel, #4 satin finish. Roll formed $1/2" \times 1/2" \times 1/2"$ channel frame has mitered corners and secured with stainless steel rivet.

Mirror: $1/4"$ thick type 1 transparent flat type, class 1 - clear glass mirrors. Mirror is coated with silver and sealed with a uniform electrolytic copper plating, along with two coats of paint for added protection. Mirrors are guaranteed against silver spoilage for a period of 15 years. Mirrors conform to ASTM C1036 and ASTM C1503-R8.

Filler: Full size, $1/8"$ shock absorbing, water resistant, nonabrasive, polyethylene padding protects all concealed mirror surfaces.

Back: #20 ga pre-plated galvanized steel, with embossed horizontal louver mounting brackets. Embossed theft resistant pressure activated clip lock device, locks mirror in place to wall hangers.

Hangers: Fabricated of #20 ga pre-plated steel galvanized steel with mounting points.

Standard Sizes Available (W x H): 16"x24", 16"x20", 16"x30", 18"x24", 18"x30", 18"x36", 20"x60", 24"x30", 24"x36", 24"x42", 24"x48", 24"x60", 24"x72", 18"x60", 24"x60", 18"x72"

Mirrors conform to Federal Specifications DD-M-00411b & DD-g-541D.

Options:

- VC: Safety Glass(Vinyl clad)
- T: Tempered Glass
- LG: Laminated Glass
- PM: Plastic Acrylic
- 8B: #8 Reflective s/s
- LX: Polycarbonate

Max size-8B mirrors: 72" x 47 1/2"

Mirrors are always ordered Width x Height

Fabricated to a tolerance of $\pm 1/8"$

Coordinate installation with architect / contractor for specific mounting location and height for each mirror application. Making sure "I" bracket is level, transfer all mounting point locations to wall surface from drawing. Secure brackets with proper fasteners for each application. Slide mirror down over horizontal brackets until clip lock secures mirror in place. Mirror can only be removed by inserting tool through hole at bottom of frame depressing clip. This will allow mirror to slide up over brackets. Fillers are available if mirrors are mounted above and below tile line. (U004 Filler) filler material will match mirror frame to form a one piece construction.

To meet ADA Code, bottom edge of reflective surface can be no higher than 40" above finished floor. (4.19.6) Full length mirrors may be used for universal application when installed in correct locations.

Abrasive cleaners & chloric solutions should not be used on mirrors. Discoloring and /or scratching of frame and reflective surface may occur.

NOTES



U840 Toilet Tissue Dispenser

Revision 03/11

JOB #:

ITEM #:

QUANTITY:

MOUNTING	HANDING	TYPE	SIZE	OTHER

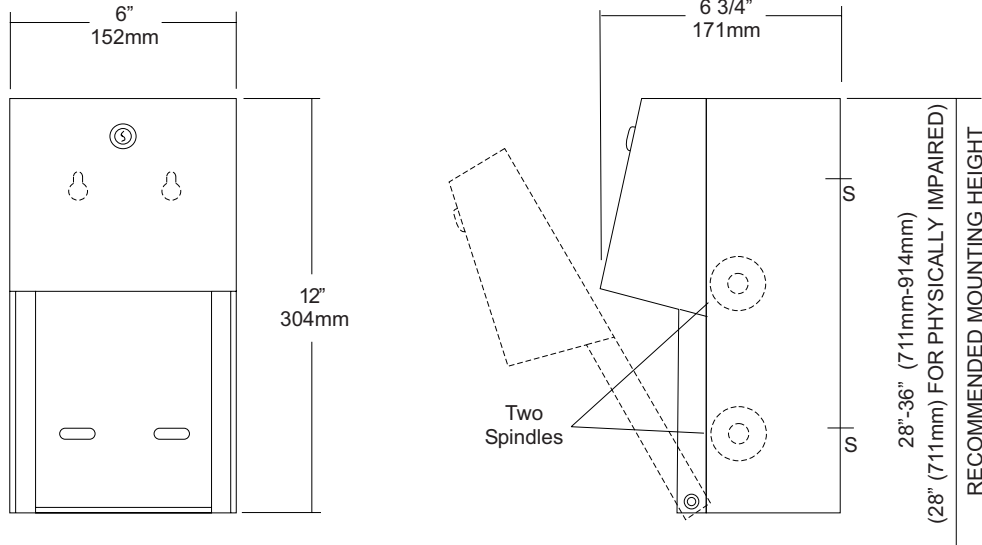

SPECIFICATIONS

- Body:** Fabricated of #22 ga stainless steel with #4 satin finish. Concealed inner dispensing mechanism is #18 ga stainless steel.
- Back:** Fabricated of #18 ga stainless steel with multiple welds to cabinet body forming a one piece construction.
- Hood:** Fabricated of #18 ga stainless steel finished to match cabinet body. Hood is secured with stainless steel hinge rivets to cabinet body. Top roll of tissue will not drop down unless the bottom roll has been depleted. When unit is closed, this will provide a theft resistant, non-control operation and reduce vandalism.
- Locks:** Pin tumbler, commercial quality locks keyed like all other AJW cabinets.
- Spindles:** (U005) Fabricated of one-piece molded high impact black ABS material.
- Overall Size:** 6"W x 12"H x 6 3/4"D
152mm x 305mm x 171mm
- Capacity:** Two standard rolls with a 5 1/4" (133mm) OD..

INSTALLATION

Provide an area on mounting surface at desired or specified location. Open cabinet, remove spindles and hold unit to wall at desired location. Transfer mounting points and drill pilot holes. Secure unit with proper fasteners per each application. Load toilet tissue on rollers, place in concealed track and close hood. Raise lower roll against upper and take hand away. Lower roll should fall into place with upper roll remaining up above the hood line. If loaded properly, top roll will not fall for use until bottom roll has been depleted. When servicing dispenser, full rolls must be used on both spindles to insure proper operation.

All toilet tissue dispensers that meet ADA code cannot have any type of control delivery. (4.16)

NOTES

Formerly Model #: U840A



UG3-A

Grab Bars

Revised 03/11

JOB #:

ITEM #:

QUANTITY:

MOUNTING	HANDING	TYPE	SIZE	OTHER

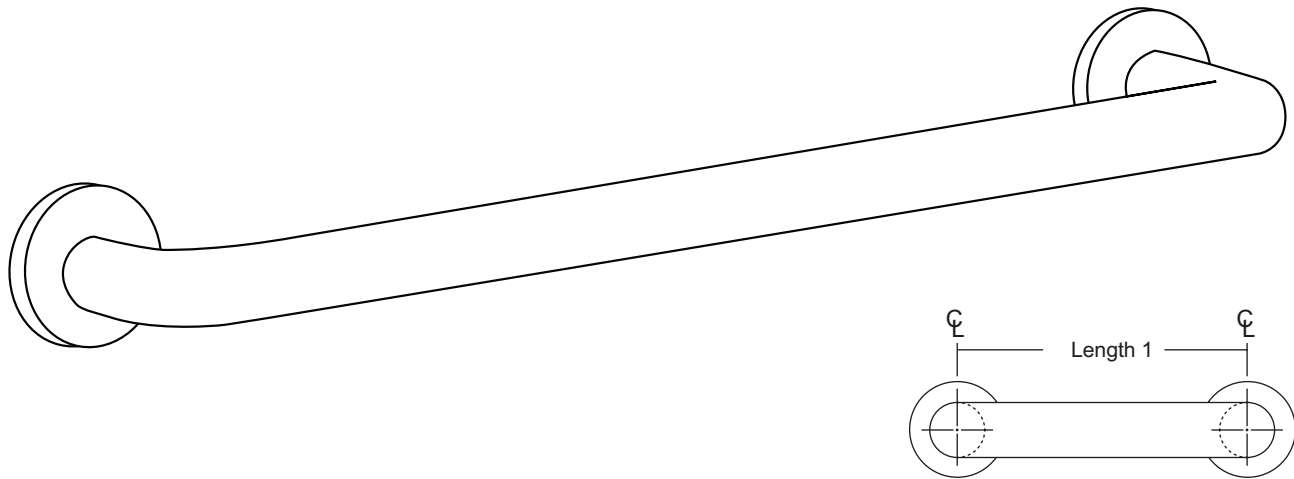

SPECIFICATIONS & INSTALLATION

Tubing: Fabricated of #18 ga stainless steel with a #4 satin finish. Available in 1 1/2" outside diameter. All bends are formed by an automatic mandrel bending process. All bars maintain a constant 1 1/2" offset.

Finish: Standard finish is a #4 satin finish. For a non-slip finish (peened) add suffix X to model number. (Ex. UG3X-A)

Flanges: Snap flanges are fabricated of 3" diameter, 3/8" deep drawn #22 ga stainless steel with #4 satin finish to match tubing. Flanges have dimples that secure over mounting plate.

Strength: Bars with a 1 1/2" offset clearance will support loads in excess of 900lbs when properly installed. Bars with greater offsets will support loads up to 250lbs when properly installed.

Installation: Before installing grab bars, verify with all state and local codes for requirements on bar diameter and type finish. Recommended mounting heights for grab bars are 33" - 36" centerline above finished floor. All mounting of grab bars when possible should have in wall mounting back plates. Find centerline mounting points and place bar on line making sure to be on center. Transfer mounting points (3 per flange) to wall. Drill pilot holes and secure bar with proper anchors per application. Snap cover over mounting plate.

Standard Lengths (Other sizes available upon request): 12", 16", 18", 24", 30", 32", 36", 42", 48", 50", 52", 54", 56"

FLANGE INFORMATION

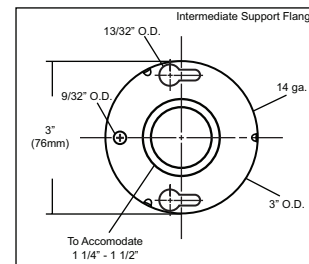
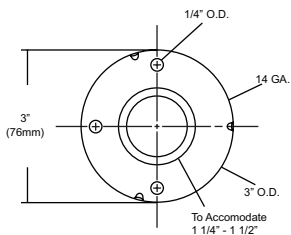
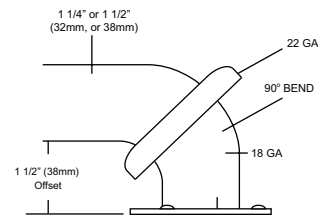

NOTES



UJ45 Series

Mop Holder & Hook Strip Combination Unit

Revision 03/11

JOB #:

ITEM #:

QUANTITY:

MOUNTING	HANDING	TYPE	SIZE	OTHER

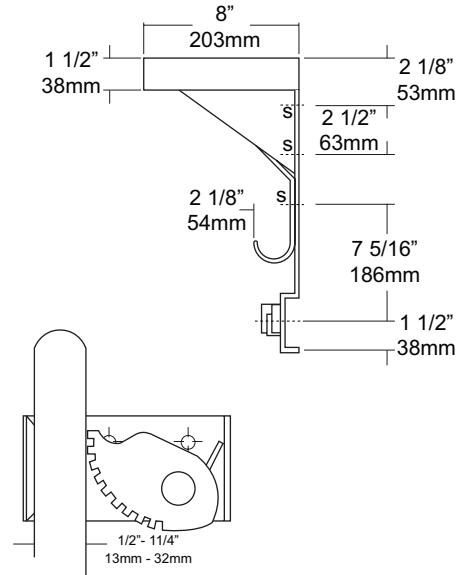
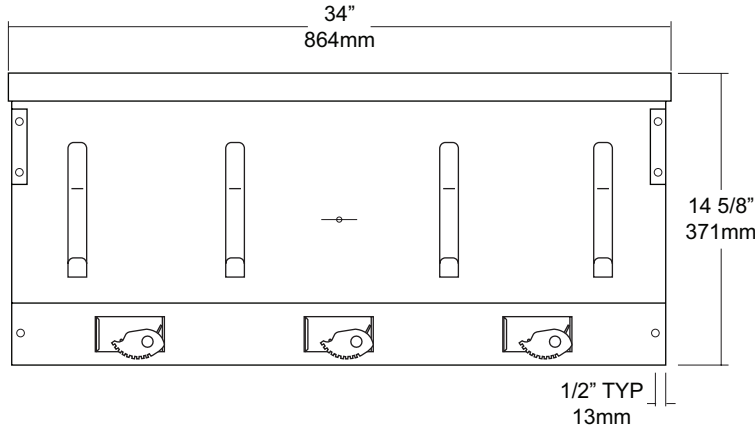

SPECIFICATIONS

Shelf: Fabricated of #18 ga stainless steel with a #4 satin finish, 8" deep (203mm) bent down 1 1/2" with 1/2" returns back for rigidity and safety.

Back: Fabricated of #18 ga stainless steel, #4 satin finish. Lower portion has a formed channel for added rigidity to support the mop holders.

Mop Holders: UJ19 plated reinforced steel with serrated cam type hard rubber mop or broom holder. Holds handles 1/2" to 1 1/4" diameter.

Hooks: #14 ga stainless steel with a #4 satin finish.

Mounting Brackets: #16 ga stainless steel with exposed mounting points.

Verify Style:

UJ45A: 34"L (864mm) with 3 holders, 4 hooks.

UJ45B: 44"L (1118mm) with 4 holders, 5 hooks.

UJ45C: 54"L (1372mm) with 5 holders, 6 hooks.

INSTALLATION

Place unit to wall surface making sure unit is level and transfer mounting points. Drill pilot holes and secure unit with proper fasteners per application.

NOTES



UX110-BF

Single Robe Hook

Revision 03/11

JOB #:

ITEM #:

QUANTITY:

MOUNTING	HANDING	TYPE	SIZE	OTHER

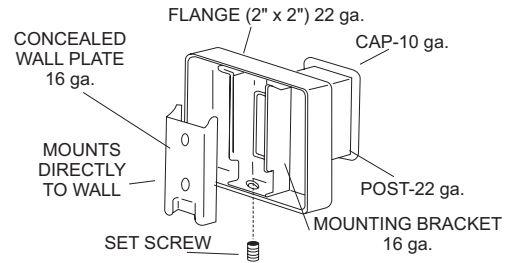
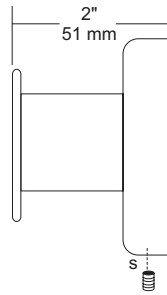
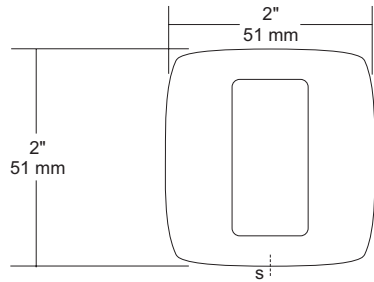

SPECIFICATIONS

UX Accessories: All UX bath accessories series are fabricated of stainless steel with a bright or satin finish. Mounting plates are concealed with a snap-on type plate secured by a set screw.

Hook: #10 ga stainless steel hook.

Flange: 2" x 2" flange #22 ga stainless steel.

Post: #22 ga stainless steel.

Mounting Plate: #16 ga concealed wall plate. Set screw secures mounting plate and flange.

Overall Size: 2"W x 2"H x 1 5/8"D

51mm x 51mm x 41mm

UX110-SF: Same as UX110-BF with satin finish

INSTALLATION

Provide an area on wall surface at desired or specified location. Place concealed mounting plate on wall surface and transfer mounting points. Drill pilot holes and secure with proper fasteners. Place snap on flange over plate and secure with set screw.

NOTES