

UX1-B-CV
 Flange & Curved Shower Rod

Revision 03/11

JOB #:

ITEM #:

QUANTITY:

MOUNTING	HANDING	TYPE	SIZE	OTHER

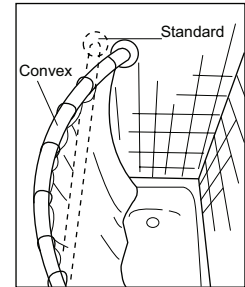
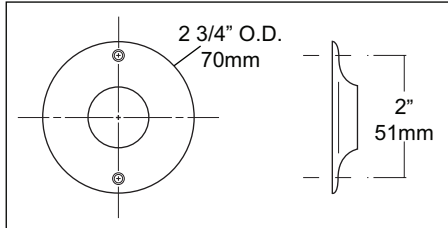
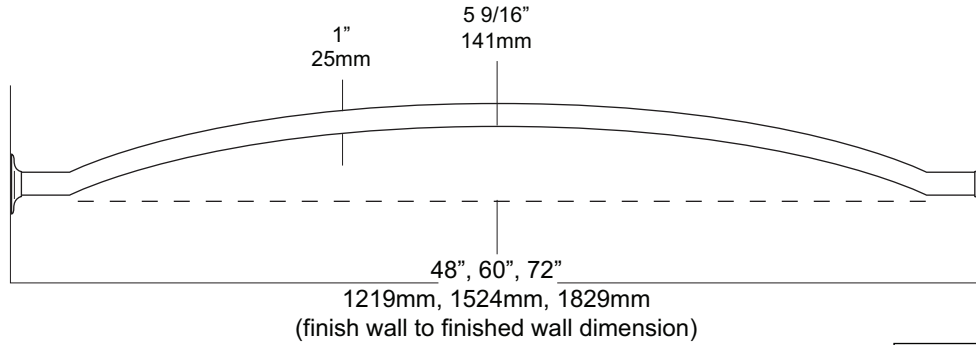

SPECIFICATIONS

Rods: Fabricated of #18 ga stainless steel with a #4 satin finish with a 1" outside diameter. Rod configuration is accomplished by a roll former that provides an additional 5 9/16" showering area. (Aprx. 25%)

Flanges: Exposed mounting stainless steel flanges have a #4 satin finish to match rod. One flange is permanently secured to the rod, the other is loose for mounting purposes. 72"L is the maximum recommended size for this style rod. Overhead supports are not required for this style rod.

Overall Size: 1" O.D.

Standard Sizes: 48", 60", 72"

INSTALLATION

Provide an area on wall surface at desired or specified location. Hold flange to wall surface and transfer mounting points. Drill pilot holes. Place flanges on the ends of the rods. Secure flanges to wall surface with proper fasteners per application. Make sure the shower rod is level before securing.

NOTES

Formerly Model #: UCVS