



Date 04/01/2014

Project Name Escuela de Ciencias de la Salud UT, Gurabo, PR

Attn Dioselyn Ares

From 145 Building Supply, Inc. / Janette Fernandez

Phone

Fax

Email

WASHROOM PARTITIONS | WASHROOM ACCESSORIES | STORAGE SYSTEMS | VISUAL DISPLAY PRODUCTS

509 TEMPLE HILL RD. NEW WINDSOR NY 12553 P. 845.562.3332 F. 845.562.3391 AJW.COM



U129PC

Vanity Mounted Soap Dispenser

Revision 07/11

JOB #:

ITEM #:

QUANTITY:

MOUNTING	HANDING	TYPE	SIZE	OTHER

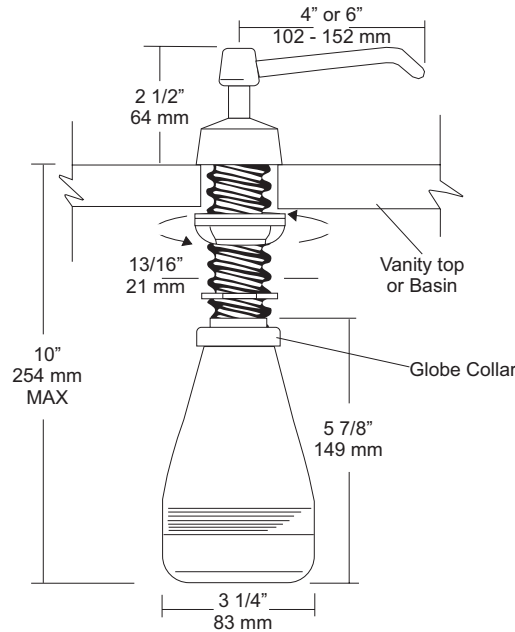

SPECIFICATIONS	INSTALLATION
----------------	--------------

Piston & Spout: Highly polished corrosion resistant, stainless steel. Assembly rotates 360 degrees.

Flange & Collar: One piece highly polished chrome on brass.

Valve Assembly: All purpose bellows valve, fabricated of ABS material, with stainless steel return spring.

Shank: Chrome on brass, secured to collar. Special key provided that unlocks collar for servicing.

Globe & Collar: High impact translucent polyethylene.

Capacity: 16 fl oz

U129PCA: Same as U129PC with 6" (152mm) spout.

Recommend type soaps without chloric solutions for proper operation.

***All vanity soap dispensers are designed to be serviced above the counter**

Provide a 7/8" - 1" diameter opening in vanity or basin. Insert shank through cut out and secure with supplied washers and wing nut. Connect supply tube with valve making sure notch end is at bottom. Secure globe and collar to shank. Fill globe above counter. Secure upper assembly to shank. Prime dispenser every time unit is serviced.

*It is not recommended to mount any soap dispenser on mirrors

**For best performance, use pre-mixed low concentrate solutions. Dispensers should have periodic maintenance performed to insure the life dispenser. Rinse out globe and valve with warm water to avoid sludge buildup.

Preventative Maintenance: Each dispenser should be flushed out aprx. Every 30 days with warm water to prevent valve from clogging with old soap. Do not use abrasive cleaners to clean dispenser.

NOTES

Formerly Model #: U129-PC



U1525EA Series

White Hands Free Dryer

Revision 03/12

JOB #:

ITEM #:

QUANTITY:

MOUNTING	HANDING	TYPE	SIZE	OTHER

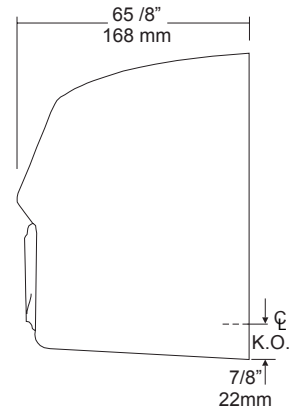
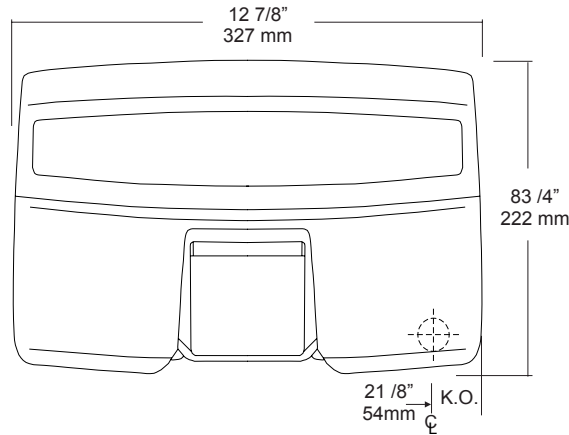
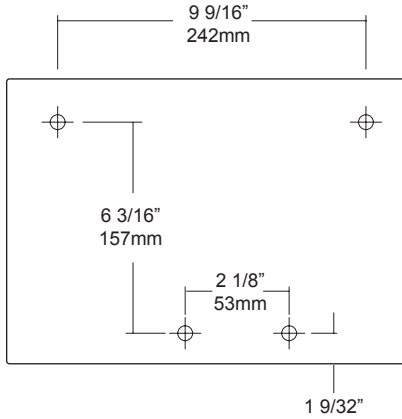

SPECIFICATIONS

- Motor:** Brushless 3450 RPM, 1/8 hp motor, capacitor initiated, thermally protected against overheating.
- Fan:** Dynamically balanced to eliminate vibration/noise.
- Heating Element:** 2300 watt nichrome wire, mounted on state of the art convective heating injection system mounted to blower housing, protected by integral safety circuit breaker.
- Timer:** Fully enclosed electronic timer that automatically turns off when hands are moved away from path of sensor.
- Electric Eye:** Sensor allows a hands free operation. When sensor beam path is disturbed, dryer will automatically turn on. When hands are moved away from beam, dryer stops.
- Cover:** Heavy die cast aluminum with baked white enamel finish and ribbed for added strength. Secured to base with two theft resistant fasteners. Chrome plated nozzle can be fixed or two position.
- Base:** One piece #14 ga steel with 3/4" returns to wall for maximum strength and rigidity.

Unit	Volts	Amps	Cycles
U1525EA-120V	110-120	20	60
U1525EA-220V	208-230	10	60

Overall Size: 12 7/8"W x 8 3/4"H x 6 5/8"D
327mm x 222mm x 168mm

INSTALLATION

Coordinate installation with contractor, architect and licensed electrician. Transfer mounting points to wall surface with supplied template. Check all code requirements for proper mounting heights. Secure base to surface with proper fasteners per application. Properly connect power supply to dryer and test operation. Secure dryer to base and test dryer again after cover is secured. Recommend 1 dryer per basin. JETAIR dryers have a full five (5) year warranty to original purchaser against defective materials and workmanship. Unit must be installed by a licensed electrician.

Mounting	Hands	Hair
Men	46" (1168mm)	73" (1854mm)
Women	44" (1118mm)	68" (1727mm)
Physically Impaired	38" (965mm)	46" (1168mm)
Children	6-10 34" (864mm)	43" (1092mm)
Children	11-14 42" (1067mm)	56" (1422mm)

*Above are recommended mounting heights from lower mounting point above the finished floor.

NOTES

Formerly Model #: U1525EA

JOB #:

ITEM #:

QUANTITY:

MOUNTING	HANDING	TYPE	SIZE	OTHER

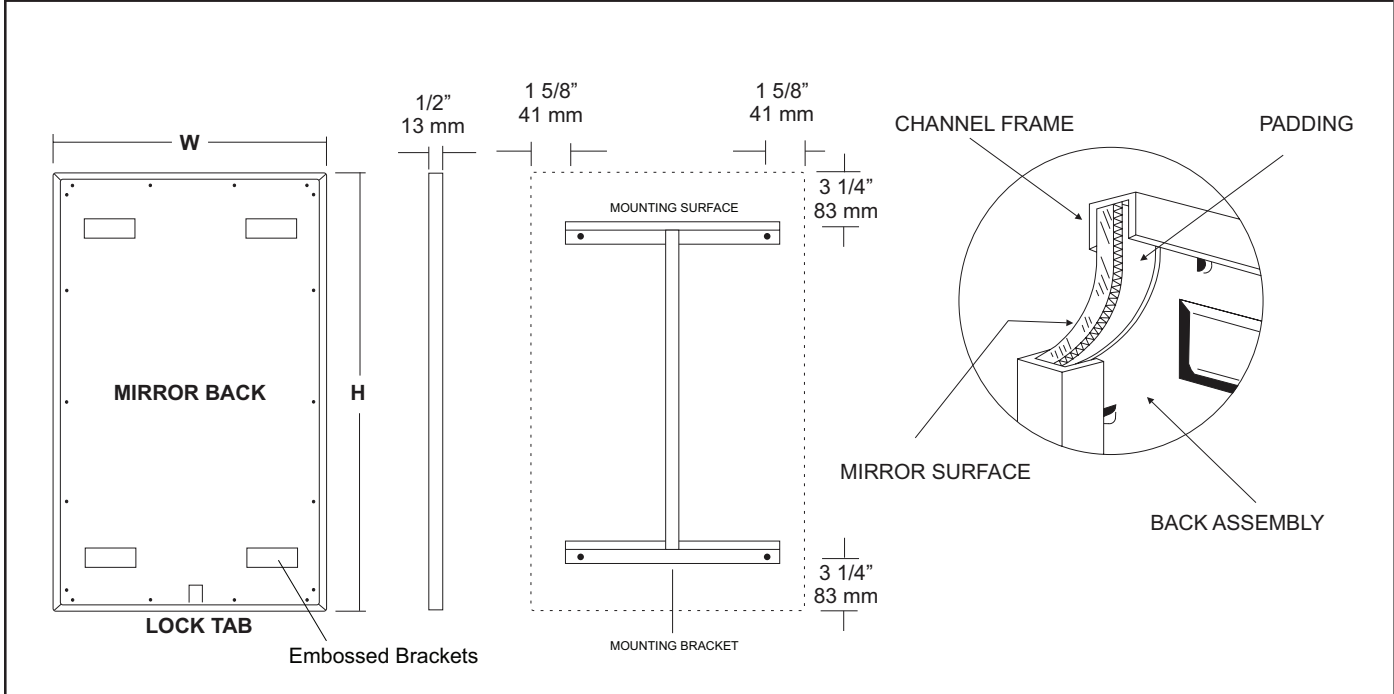

SPECIFICATIONS

Frame: Fabricated of #20 ga stainless steel, #4 satin finish. Roll formed 1/2" x 1/2" x 1/2" channel frame has mitered corners and secured with stainless steel rivet.

Mirror: 1/4" thick type 1 transparent flat type, class 1 - clear glass mirrors. Mirror is coated with silver and sealed with a uniform electrolytic copper plating, along with two coats of paint for added protection. Mirrors are guaranteed against silver spoilage for a period of 15 years. Mirrors conform to ASTM C1036 and ASTM C1503-R8.

Filler: Full size, 1/8" shock absorbing, water resistant, nonabrasive, polyethylene padding protects all concealed mirror surfaces.

Back: #20 ga pre-plated galvanized steel, with embossed horizontal louver mounting brackets. Embossed theft resistant pressure activated clip lock device, locks mirror in place to wall hangers.

Hangers: Fabricated of #20 ga pre-plated steel galvanized steel with mounting points.

Standard Sizes Available (W x H): 16"x24", 16"x20", 16"x30", 18"x24", 18"x30", 18"x36", 20"x60", 24"x30", 24"x36", 24"x42", 24"x48", 24"x60", 24"x72", 18"x60", 24"x60", 18"x72"

Mirrors conform to Federal Specifications DD-M-00411b & DD-g-541D.

Options:

- VC: Safety Glass(Vinyl clad)
- T: Tempered Glass
- LG: Laminated Glass
- PM: Plastic Acrylic
- 8B: #8 Reflective s/s
- LX: Polycarbonate

Max size-8B mirrors: 72" x 47 1/2"

Mirrors are always ordered Width x Height

Fabricated to a tolerance of ± 1/8"

INSTALLATION

Coordinate installation with architect / contractor for specific mounting location and height for each mirror application. Making sure "I" bracket is level, transfer all mounting point locations to wall surface from drawing. Secure brackets with proper fasteners for each application. Slide mirror down over horizontal brackets until clip lock secures mirror in place. Mirror can only be removed by inserting tool through hole at bottom of frame depressing clip. This will allow mirror to slide up over brackets. Fillers are available if mirrors are mounted above and below tile line. (U004 Filler) filler material will match mirror frame to form a one piece construction.

To meet ADA Code, bottom edge of reflective surface can be no higher than 40" above finished floor. (4.19.6) Full length mirrors may be used for universal application when installed in correct locations.

Abrasive cleaners & chloric solutions should not be used on mirrors. Discoloring and /or scratching of frame and reflective surface may occur.

NOTES

JOB #:

ITEM #:

QUANTITY:

MOUNTING	HANDING	TYPE	SIZE	OTHER

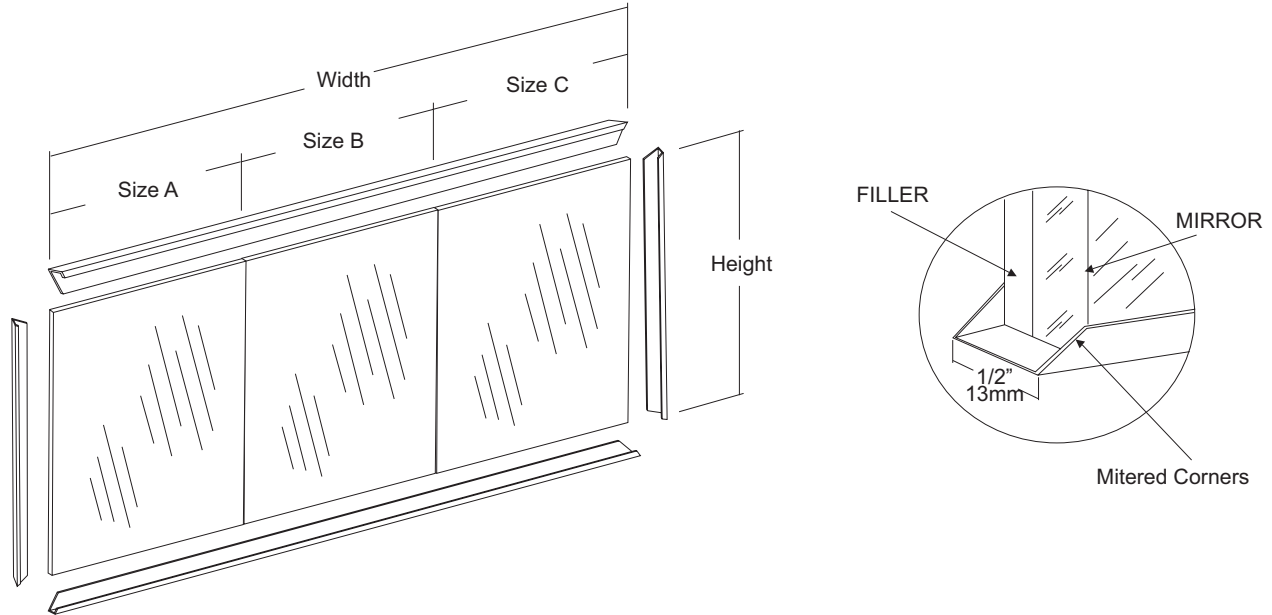

SPECIFICATIONS

Mirror: 1/4" thick type 1 transparent flat type, class 1 - clear glass mirrors. Mirror is coated with silver and sealed with a uniform electrolytic copper plating, along with two coats of paint for added protection. Mirrors are guaranteed against silver spoilage for a period of 15 years. Mirrors conform to ASTM C1036 and ASTM C1503-R8.

Frame: #18 ga stainless steel with a #4 satin finish. (1/2" x 1/2" x 1 3/4" channel)

Backing: 1/4" thick tempered Masonite backing strips.

Optional Surfaces & Sizes:

- PM: Plastic Mirrors (96" x 48" max size for 1 piece of glass)
- PG: Plate Glass (Floor) (96" x 48" max size for 1 piece of glass)
- LG: Laminated Glass (96" x 48" max size for 1 piece of glass)
- T: Tempered Mirror (96" x 48" max size for 1 piece of glass)
- VC: Vinyl Clad (96" x 48" for 1 piece of glass)

When mirrors are fabricated with multiple pieces of glass, size of each piece must be specified.

Mirrors are always ordered Width x Height

Fabricated to a tolerance of ± 1/8"

INSTALLATION

Mount the bottom channel at desired or specified location. Place a level across the channel to make sure mirror will be level. Place glass and Masonite strips (vertical) in channel and check with level again. Clips are required on the top for securing mirror properly. (SCL-J: stainless steel clips). Measure from the bottom "J" mold up height of mirror and strike a line. Mount top "J" the same way allowing 3/4" to lock glass in place. Place glass and Masonite in channel and slide top "J" down to lock in place. Follow the same instructions for top and bottom style and add the two side "J" channel.

The bottom reflective surface edge must be mounted 40" above finished floor to comply with ADA code, 4.19.6.

NOTES



U838

Jumbo Roll Toilet Tissue Dispenser

Revision 02/14

JOB #:

ITEM #:

QUANTITY:

MOUNTING	HANDING	TYPE	SIZE	OTHER

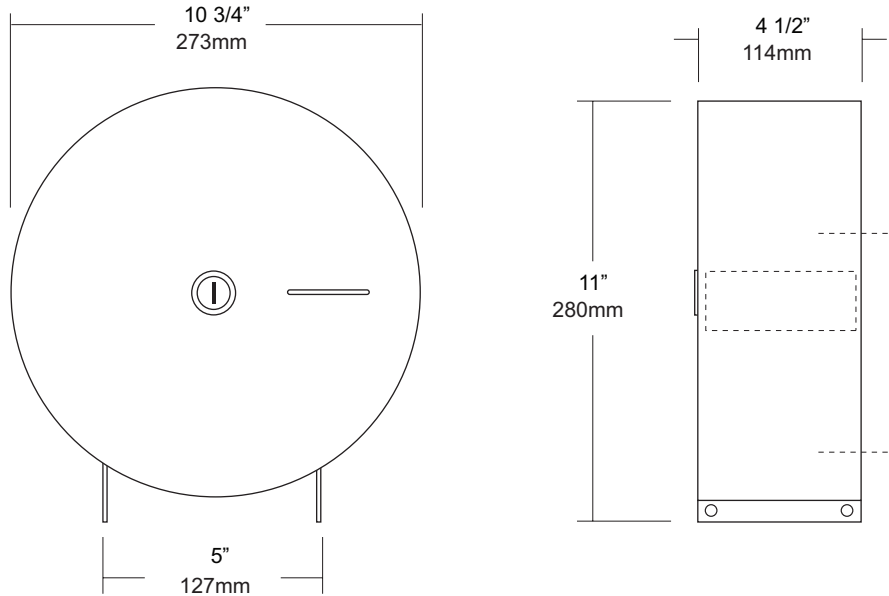

SPECIFICATIONS

Cabinet: Fabricated of #20 ga stainless steel with a #4 satin finish, and stainless steel pivot hinges that secure cabinet to mounting bracket. Body equipped with refill viewer. Non-control delivery system complies with ADA code.

Dispensing Area: Paper is dispensed without any sharp edges.

Locks: Special keyed lock secures cabinet to non-removable spindle.

Overall Size: 10 3/4"W x 11"H x 4 1/2"D

273mm x 279mm x 114mm

Capacity: One 9" OD or 10" OD jumbo tissue roll

INSTALLATION

Provide an area on wall at desired or specified location. Unlock cabinet and place unit on wall making sure cabinet is level. Transfer mounting points to surface and drill pilot holes. Secure unit with proper fasteners per application. Load toilet tissue on spindle and close cabinet.

Toilet Paper Dispensers: All dispensers that are to meet ADA code cannot have any type of controlled delivery. (4.16)

NOTES

JOB #:

ITEM #:

QUANTITY:

MOUNTING	HANDING	TYPE	SIZE	OTHER

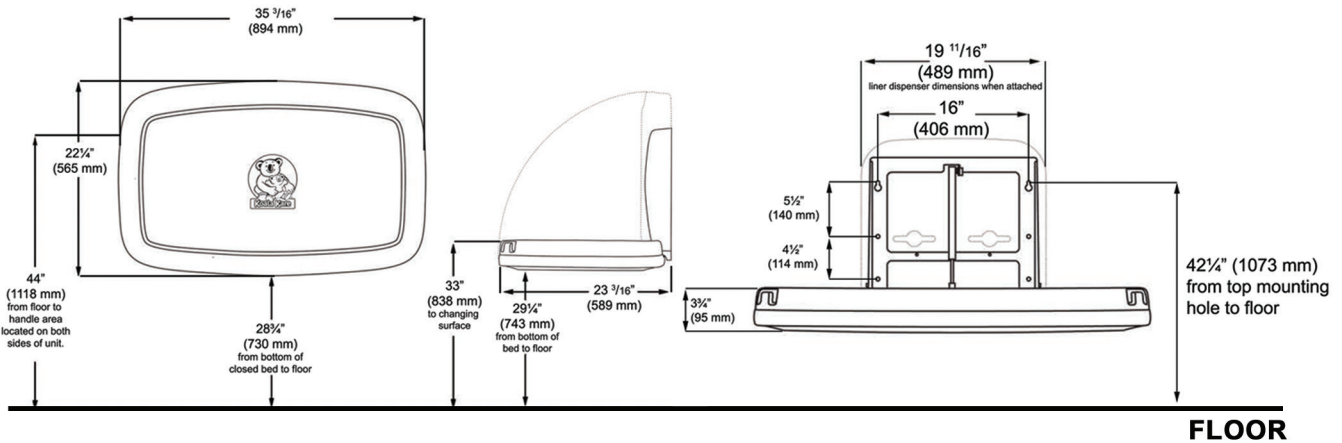

SPECIFICATIONS

Body: FDA approved injection molded polypropylene with Microban antimicrobial additive. Reinforced steel-on-steel hinge mechanism and metal mounting chassis. Labeled usage instructions and safety messages in four languages.

Liner Dispenser: An integral part of body that is standard with each unit. (Capacity: 50)

Pneumatic Cylinder: Concealed pneumatic cylinder & hinge structure provides controlled and smooth open and close motion.

Safety Straps: Nylon safety strap snap lock fastens to hold child securely in place.

Overall Size: 35 3/16"W x 22 1/4"H x 4"D (closed) 23 3/16"D (open)

894mm x 565mm x 102mm (closed), 589mm (open)

Available Colors: Cream & Grey

INSTALLATION

Coordinate installation with architect or contractor to avoid interference with surrounding objects. Hold unit up to wall and open to verify there are no obstructions to interfere with operation of station. From finished floor to the top of the unit closed should be at a height of 48". Transfer mounting point locations to wall surface and drill pilot holes. Secure unit with proper fasteners for each application. (Recommend a qualified carpenter to install unit) Unit can be lowered with one hand and into position with less than 5 lbs of force, wall opening turning or twisting of wrist. Verify with local codes and type approach (forward or side) for proper mounting height above finished floor. Unit can support up to 200lbs when properly installed.

Unit should be cleaned once or more daily with a clean nylon brush and spray disinfectant.

When properly installed, baby changing stations comply with ASTM static load performance requirements.

NOTES

Formerly Model #: U945H

JOB #:

ITEM #:

QUANTITY:

MOUNTING	HANDING	TYPE	SIZE	OTHER

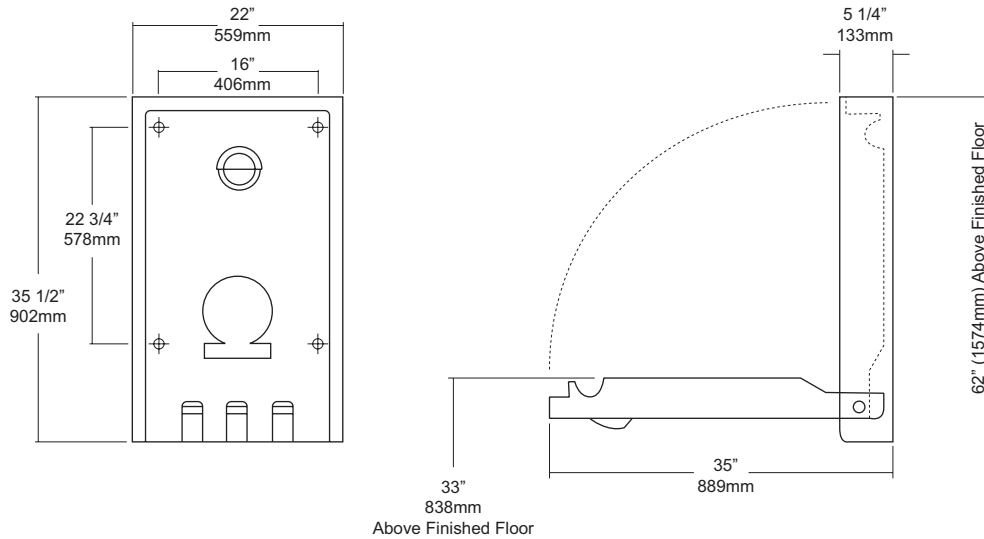

SPECIFICATIONS

Body: Fabricated of high impact ABS polyethylene with radius leading edges that prevent injury. Embedded Microban antimicrobial is odor resistant and easy to clean. Base is concave formed to allow safe and easy changing. Molded graphics and brail to comply with ADA.

Liner Dispenser: An integral part of body that is standard with each unit.

Pneumatic Cylinder: Concealed pneumatic cylinder & hinge structure provides controlled and smooth open and close motion.

Safety Straps: Snap lock fasteners to hold child securely in place.

Overall Size: 22"W x 35 1/2"H x 5 1/4"D (closed) 35"D (open)
559mm x 902mm x 133mm (closed) 889mm (open)

Colors Available: Cream, Grey

INSTALLATION

Coordinate installation with architect or contractor to avoid interference with surrounding objects. Hold unit up to wall and open to verify there are no obstructions to interfere with operation of station. Transfer mounting point locations to wall surface and drill pilot holes. Secure unit with proper fasteners for each application. (Recommend a qualified carpenter to install unit) Unit can be lowered with one hand and into position with less than 5 lbs of force, wall openingut turning or twisting of wrist. Verify with local codes and type approach (forward or side) for proper mounting height above finished floor.

Unit should be cleaned once or more daily with a clean nylon brush and spray disinfectant.

When properly installed, baby changing stations comply with ASTM static load performance requirements.

NOTES

Formerly Model #: U945V



UG2-A

Grab Bars

Revised 03/11

JOB #:

ITEM #:

QUANTITY:

MOUNTING	HANDING	TYPE	SIZE	OTHER

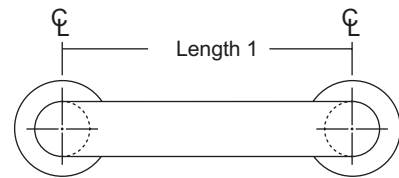
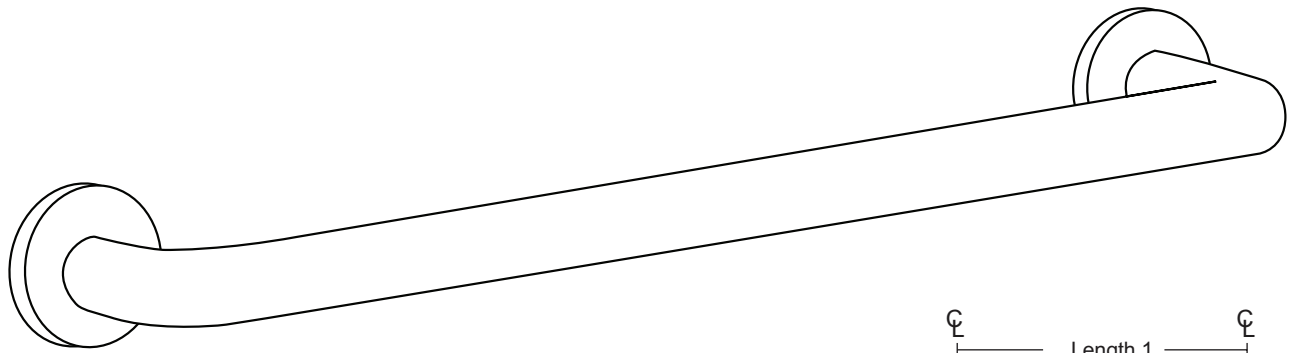

SPECIFICATIONS & INSTALLATION

Tubing: Fabricated of #18 ga stainless steel with a #4 satin finish. Available in 1 1/4" outside diameter. All bends are formed by an automatic mandrel bending process. All bars maintain a constant 1 1/2" offset.

Finish: Standard finish is a #4 satin finish. For a non-slip finish (peened) add suffix X to model number. (Ex. UG2X-A)

Flanges: Snap flanges are fabricated of 3" diameter, 3/8" deep drawn #22 ga stainless steel with #4 satin finish to match tubing. Flanges have dimples that secure over mounting plate.

Strength: Bars with a 1 1/2" offset clearance will support loads in excess of 900lbs when properly installed. Bars with greater offsets will support loads up to 250lbs when properly installed.

Installation: Before installing grab bars, verify with all state and local codes for requirements on bar diameter and type finish. Recommended mounting heights for grab bars are 33" - 36" centerline above finished floor. All mounting of grab bars when possible should have in wall mounting back plates. Find centerline mounting points and place bar on line making sure to be on center. Transfer mounting points (3 per flange) to wall. Drill pilot holes and secure bar with proper anchors per application. Snap cover over mounting plate.

Standard Lengths (Other sizes available upon request): 12", 16", 18", 24", 30", 32", 36", 42", 48", 50", 52", 54", 56"

FLANGE INFORMATION

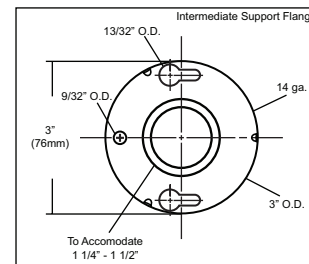
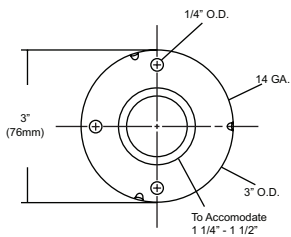
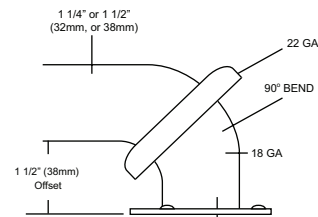

NOTES



UJ41 Series

Mop Holder & Hook Strip Combination Unit

Revision 03/11

JOB #:

ITEM #:

QUANTITY:

MOUNTING	HANDING	TYPE	SIZE	OTHER

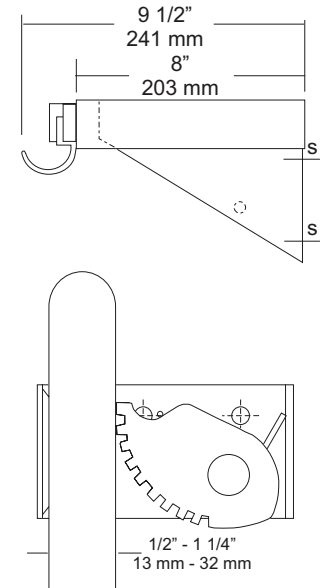

SPECIFICATIONS

Shelf: Fabricated of #18 ga stainless steel with a #4 satin finish, 8" deep (203mm) bent down 1 1/2" with 1/2" returns back for rigidity and safety.

Mop Holders: UJ19 plated reinforced steel with serrated cam type hard rubber mop or broom holder. Holds handles 1/2" to 1 1/4" diameter.

Rag Hooks: Fabricated of #18 ga stainless steel with a #4 satin finish.

Mounting Brackets: #16 ga stainless steel with exposed mounting points.

Drying Rod: 1/4" diameter stainless steel rod, secured to outside of support/mounting brackets with locking caps.

Verify Style:

UJ41A: 30"L (762mm) with 3 holders, 2 hooks.
Rod Length: 21 3/8" (565mm)

UJ41B: 36"L (914mm) with 4 holders, 3 hooks.
Rod Length: 27 3/8" (692mm)

UJ41C: 42"L (1066mm) with 5 holders, 4 hooks.
Rod Length: 33 3/8" (845mm)

UJ41D: 48"L (1219mm) with 6 holders, 5 hooks.
Rod Length: 39 3/8" (997mm)

INSTALLATION

Place unit to wall surface making sure unit is level and transfer mounting points. Drill pilot holes and secure unit with proper fasteners per application.

NOTES



UX143-BF

Door Bumper

Revision 03/11

JOB #:

ITEM #:

QUANTITY:

MOUNTING	HANDING	TYPE	SIZE	OTHER

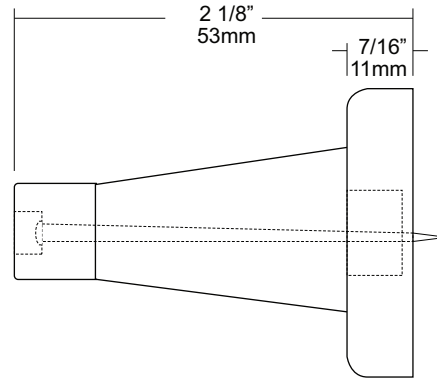
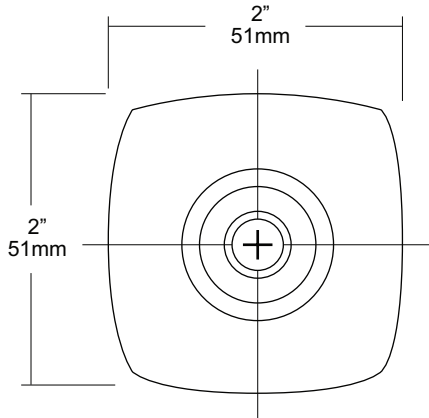

SPECIFICATIONS

Post / Bumper: Black nylon post with a neoprene tip with Phillips head fastener to secure to wall surface.

Flange: 2" x 2" flange #22 ga bright stainless steel.

Overall Size: 2"W x 2"H x 2 1/8"D

51mm x 51mm x 54mm

UX143-SF: Same as UX143 with satin finish flange.

INSTALLATION

Provide an area on wall surface at desired or specified location. Assemble post into mounting plate and transfer mounting points. Drill pilot hole and secure with proper fastener. Secure provided fastener into wall surface into in wall backing. (Ex: stud or other proper anchoring devices)

NOTES

Formerly Model #: UX143