



Date 10/04/2013
Project Name DFD
Attn
From
Phone
Fax
Email WFONG@HIRSCH.COM

WASHROOM PARTITIONS | WASHROOM ACCESSORIES | STORAGE SYSTEMS | VISUAL DISPLAY PRODUCTS

509 TEMPLE HILL RD. NEW WINDSOR NY 12553 P. 845.562.3332 F. 845.562.3391 AJW.COM

MOUNTING	HANDING	TYPE	SIZE	OTHER

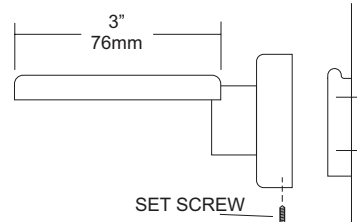
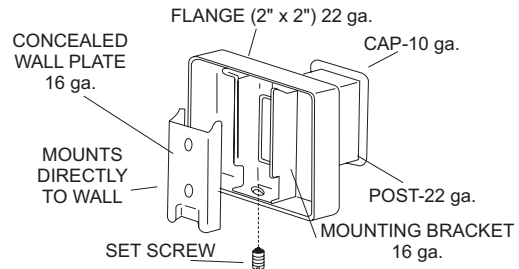
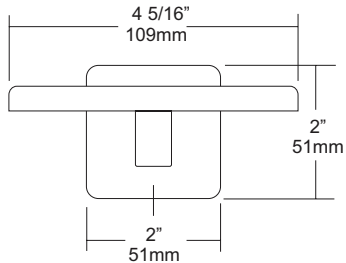
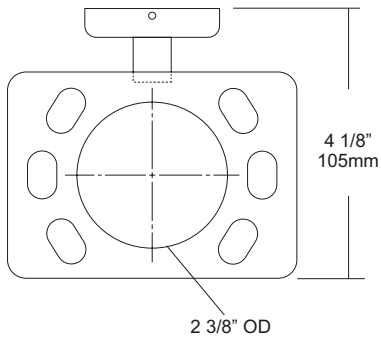

SPECIFICATIONS

UX Accessories: All UX bath accessories series are fabricated of stainless steel with a bright or satin finish. Mounting plates are concealed with a snap-on type plate secured by a set screw.

Flange: 2" x 2" flange #22 ga stainless steel.

Post: #22 ga stainless steel.

Mounting Plate: #16 ga concealed wall plate. Set screw secures mounting plate and flange.

Tumbler Holder: #22 ga stainless steel.

Overall Size: 4 5/16"W x 2"H x 4 1/8"D

110mm x 51mm x 105mm

UX120-SF: Same as UX120-BF with satin finish.

INSTALLATION

Provide an area on wall surface at desired or specified location. Place concealed mounting plate on wall surface and transfer mounting points. Drill pilot holes and secure with proper fasteners. Place snap on flange over plate and secure with set screw.

NOTES