



Date

Project Name

Attn

From

Phone

Fax

Email

WASHROOM PARTITIONS | WASHROOM ACCESSORIES | STORAGE SYSTEMS | VISUAL DISPLAY PRODUCTS

509 TEMPLE HILL RD. NEW WINDSOR NY 12553 P. 845.562.3332 F. 845.562.3391 AJW.COM



U1511EA Series

Low Profile Hands Free Dryer with
Universal Voltage

Revision 03/12

JOB #:

ITEM #:

QUANTITY:

MOUNTING	HANDING	TYPE	SIZE	OTHER

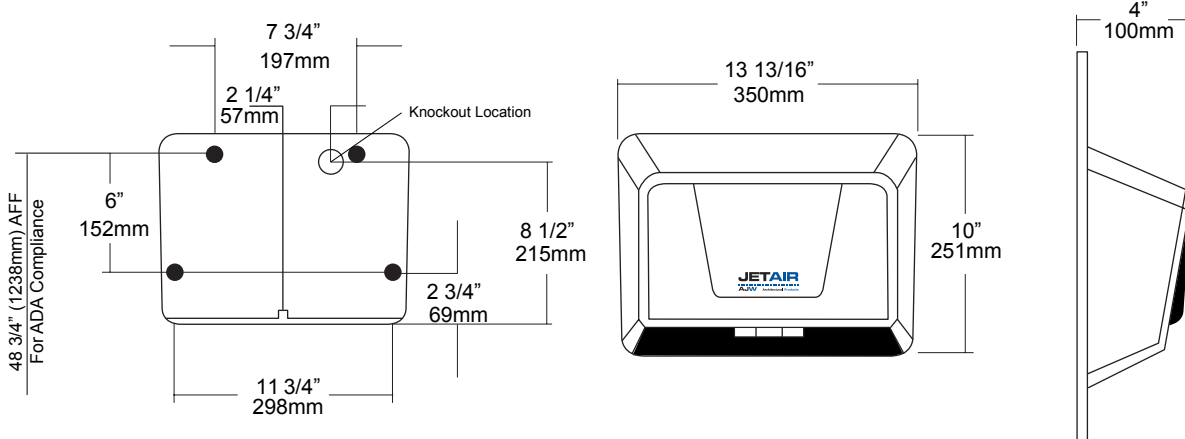

SPECIFICATIONS

Element: Industrial strength coil wound on mica support protected by temperature limit.

Circuitry: Infrared microprocessor control allows multi- voltage application.

Assembly: Dual blower wheel and housing made of engineered thermoplastics powered by thermally protected brush motor. Assembled on a plated steel base plate for maximum strength and durability.

Cover and Finish:

U1511EA: Powder coated (white) formed steel alloy. Cover secured to base with theft resistant screws.

U1511EA-SF: satin stainless steel cover.

Overall Size: 13"W x 10"H x 4"D

Specifications:

Motor: 7500 RPM (Brushed motor)

Sound Level: 73 DB

Volts	Watts	Amps	Frequency
110-120	1800	15	50 hz or 60 hz
208-240	2400	10	50 hz or 60 hz

INSTALLATION

Coordinate installation with architect and contractor avoid interference with pipes, vents etc. Verify mounting height for each application for code compliance. Place template on wall surface and transfer mounting points, Drill holes for securing making sure power source is not be interrupted when base is installed, Remove cover. Unit must be installed by qualified licensed electricians. Properly connect power supply and test dryer for proper operation, Install cover and secure with theft resistant fasteners and test again. (15 second delay from when power is connected to when unit is operational)

NOTES

Formerly Model #: U1511EA