



# UX60-BF

Soap Dish

Revision 03/11

JOB #:

ITEM #:

QUANTITY:

MOUNTING	HANDING	TYPE	SIZE	OTHER

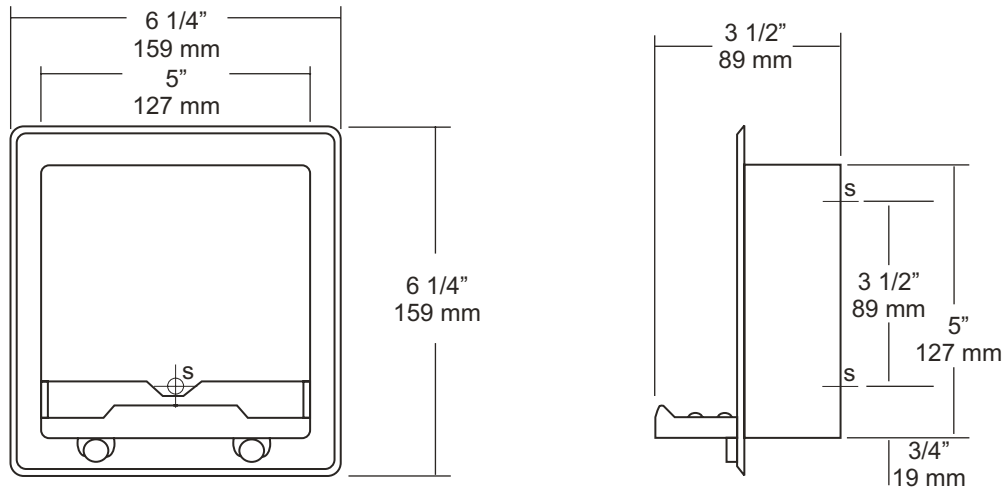

### SPECIFICATIONS

**Shell:** Drawn one piece construction fabricated of #22 gauge stainless steel with a bright finish. Two mounting points allow unit to be secured to mounting clamps or framing in wall opening.

**Soap Holder:** Fabricated of high impact clear ABS material that snaps in place on two exposed pins on the front face of the unit.

**Overall Size:** 6 1/4"W x 6 1/4"H x 3 1/2"D

**165mm x 165mm x 89mm**

**Wall Opening:** 5 1/4"W x 5 1/4"H x 2"D

**133mm x 133mm x 51mm**

### INSTALLATION

Provide a wall opening at desired or specified area and coordinate with contractor or architect to avoid interference with pipes, vents, etc. Secure unit in wall opening with proper fasteners and/or clamps required per each application.

Mounting Clamps:

"A" Clamp: Applicable where backing or framing is not available. Used on existing walls.

"B" Clamp: Conventional type clamp, secured to back side of front wall.

### NOTES