



UJ13B

MOP HOLDER WITH UTILITY SHELF

Job #:

Item #:

Quantity:

MOUNTING	HANDING	TYPE	SIZE	OTHER

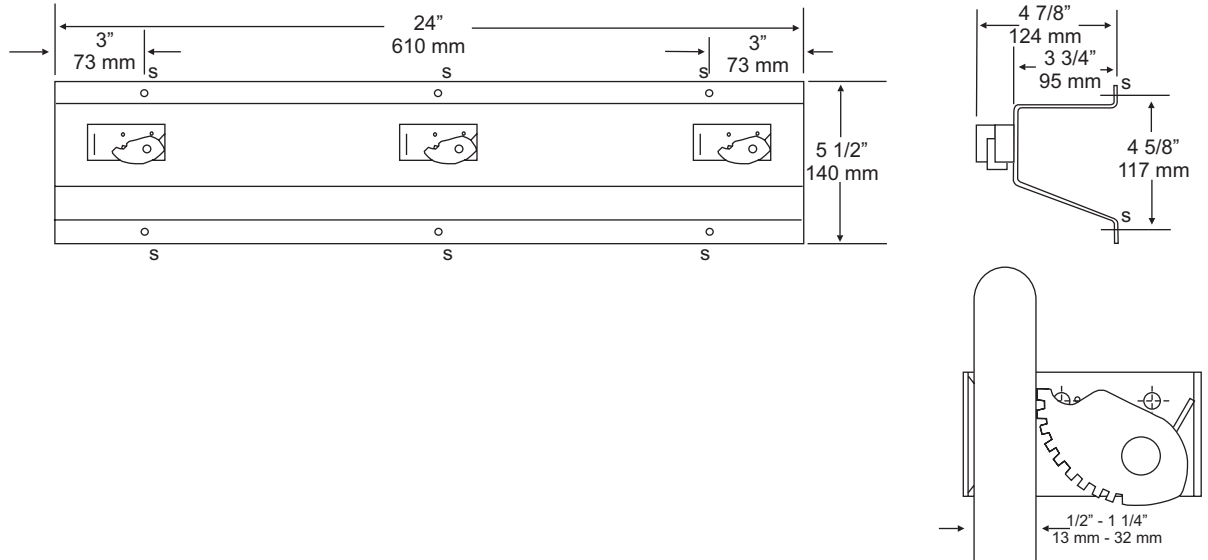

SPECIFICATIONS

Mop Strip & Shelf: Type 304 #18 ga stainless steel with a #4 satin finish. Upper portion of strip is formed in the shape of a "hat" channel, that is utilized as a shelf, projects 3 3/4" from wall surface. Lower portion is angled to add rigidity and strength to strip.

Mop Holders: UJ19 plated reinforced steel with serrated cam type hard rubber mop or broom holder. Holds handles 1/2" to 1 1/4" diameter.

Verify Style:

- UJ13A:** 24"L (610mm) with 3 holders.
- UJ13B:** 36"L (914mm) with 4 holders.
- UJ13C:** 48"L (1219mm) with 5 holders.
- UJ13D:** 60"L (1524mm) with 6 holders.

INSTALLATION

Place unit to wall surface making sure unit is level and transfer mounting points. Drill pilot holes and secure unit with proper fasteners per application.

NOTES