



UJ12A
MOP HOLDER STRIP

Job #:

Item #:

Quantity:

MOUNTING	HANDING	TYPE	SIZE	OTHER

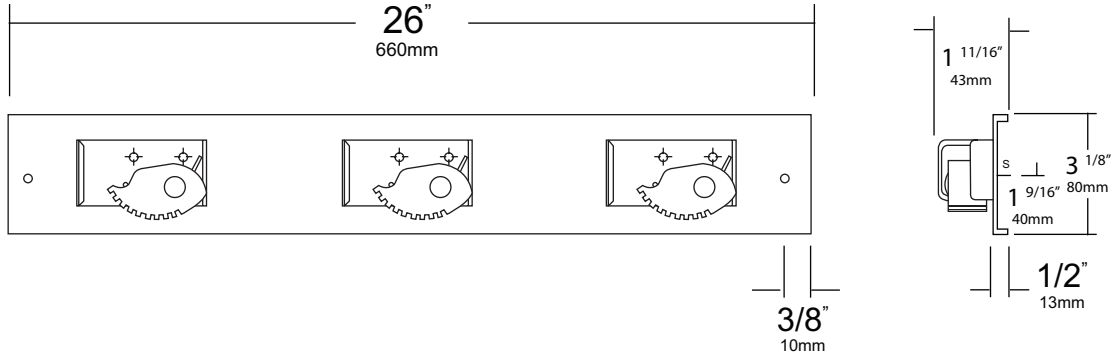

SPECIFICATIONS

Mop Strip: Strip is fabricated of type 304 stainless steel #20 gauge with a #4 satin finish. Top and bottom leading edges are returned to wall 1/2" for rigidity.

Mop Holders: Holders are fabricated of plated reinforced steel with a serrated cam type holder. Cam will hold a handle of 1/2"-1 1/4" diameter.

UJ12A: 26"L with three (3) holders.

UJ12B: 36"L with four (4) holders.

UJ12C: 46"L with five (5) holders.

UJ12D: 56"L with six (6) holders.

INSTALLATION

Place unit to wall surface making sure unit is level and transfer mounting points. Drill pilot holes and secure unit with proper fasteners per application.

NOTES