

Job #:

Item #:

Quantity:

MOUNTING	HANDING	TYPE	SIZE	OTHER
----------	---------	------	------	-------

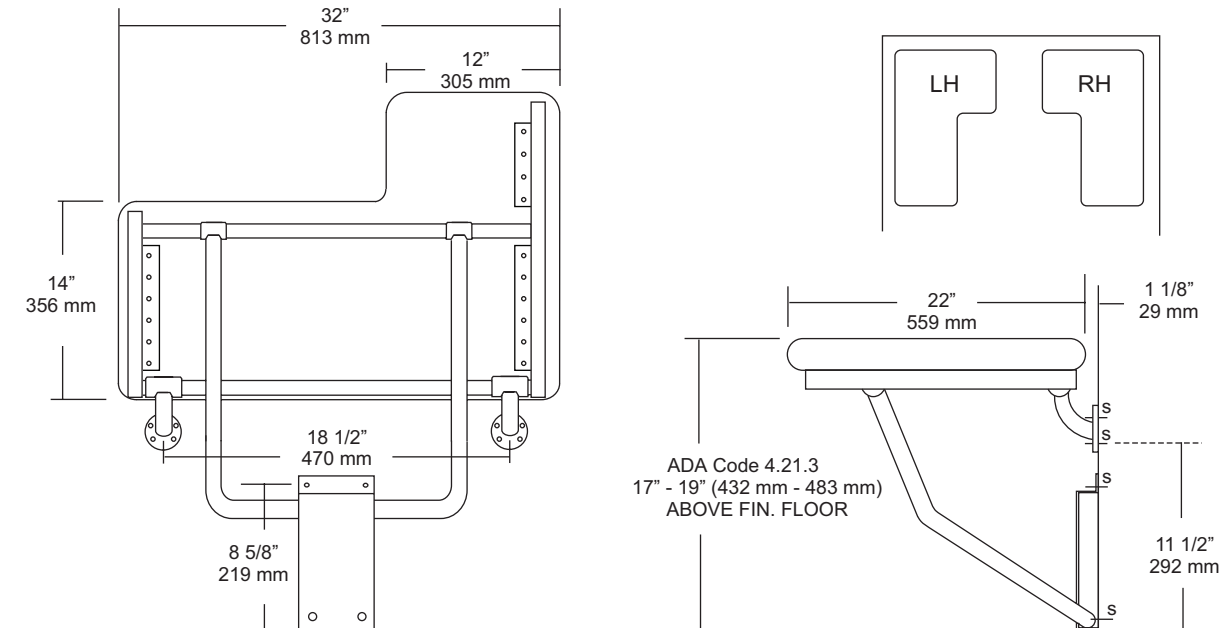

SPECIFICATIONS

Seat: Fabricated of 2 1/2" thick, naugahyde cushion (white) seamless design with all leading edges having a radius. Seat is secured to a 1/2" thick marine plywood.

Tubing: Fabricated of type 304 #11s ga stainless steel with #4 satin finish.

Main Frame: Type 304 #18 ga 1 1/4" with satin finish tubing. Underside has no exposed fasteners.

Flanges: Type 304 #11 gauge stainless steel with four (4) exposed mounting points. Under slung supports have a 1 1/4" OD. (Satin finish)

Mounting Bracket: Type 304 #16 ga stainless steel "hat" style bracket with 4 mounting support points. Bracket acts as a guide to raise and lower seat platform and is equipped with four (4) points to secure to wall surface. For maximum support, bracket is mounted so the bottom is set on the finished floor surface.

Overall Size: 32"W x 22"D (seating area)
813mm x 559mm

Specify right (U933-1AR) or left (U933-1AL) hand seat.

INSTALLATION

To comply with ADA Code, seat should be mounted at a height 17" - 19" above finished floor. Check all state and local codes for proper mounting requirements. Recommend in wall mounting on all shower seats. (BP10) Place seat up against wall making sure the extended part of seat has an offset no more than 1 1/2" away from wall. (Same as grab bar) Transfer mounting points to wall surface and drill pilot holes. Secure seat to surface with proper fasteners per each application. Snugly secure seat to surface and check seat to be level. If seat is level raise and lower seat to check path of travel. Finish securing seat after checking seat for proper operation. When properly mounted seat will support up to 250 lbs and will conform with ADA Code 4.21.3 and 4.26.3

NOTES

