



U7311
Medicine Cabinet

Revision 11/11

JOB #:

ITEM #:

QUANTITY:

MOUNTING	HANDING	TYPE	SIZE	OTHER

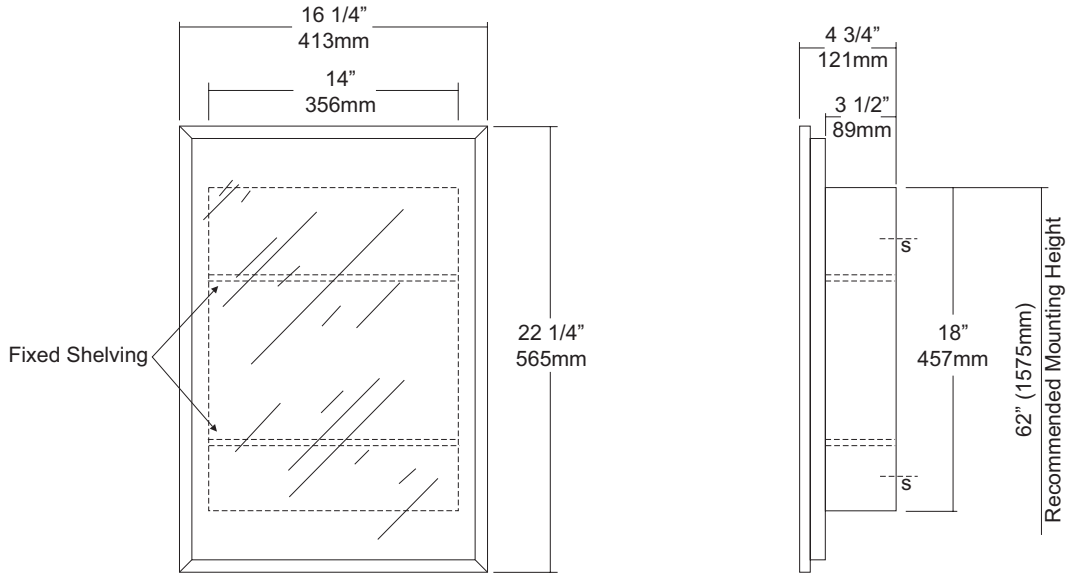

SPECIFICATIONS

Cabinet Body: Fabricated of heavy duty, high impact polystyrene with a baked white finish that is rust resistant.

Mirror Door: Fabricated is fabricated of float plate glass, silver coated and sealed with an electrolytic copper plating. Door is kept closed by means of a magnetic catch and secured to body with pin hinges.

Mirror Frame: Fabricated of bright polished steel channel.

Shelving: Equipped with 2 fixed shelves.

Overall Size: 16 1/4"W x 22 1/4"h x 4 3/4"D
413mm x 565mm x 121mm

Wall Opening: 14"W x 18"H x 3 1/2"D
356mm x 457mm x 89mm

INSTALLATION

Coordinate installation with architect and or contractor. Provide a wall opening 14"W x 18"H x 3 1/2"D. Place cabinet in wall opening and secure with proper fasteners per application. Place unit on wall surface and make sure unit is level. Transfer mounting points and drill pilot holes. Secure unit to surface using proper fasteners per application.

To meet ADA code, a usable shelf on cabinet cannot be any higher than 44" (1120mm) above the finished floor. (4.2.4)

NOTES