

Job #:

Item #:

Quantity:

MOUNTING	HANDING	TYPE	SIZE	OTHER

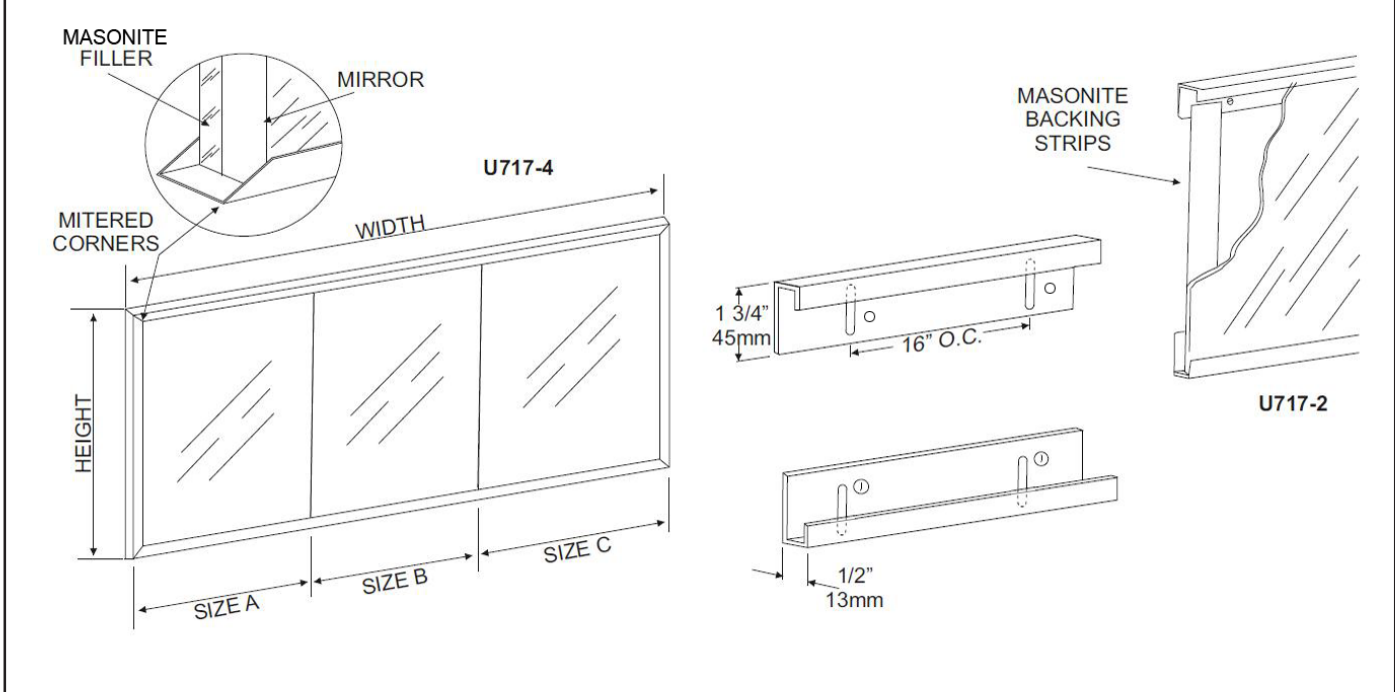

SPECIFICATIONS	INSTALLATION
----------------	--------------

Mirror: Mirror is fabricated of #1 quality, 1/4" thick polished plate glass, silver coated and sealed with a uniform coating of electrolytic copper plating. Mirrors are provided with a smooth polished edges for safety. Plate glass mirrors are guaranteed against silver spoilage for a period of 15 years and conform to Federal Specifications DD-G-451D.

Frame: Type 304 #18 ga stainless steel with a #4 satin finish. (1/2" x 1/2" x 1 3/4" channel)

Backing: 1/4" thick tempered Masonite backing strips.

OPTIONAL SURFACES & SIZES:

PM: Plastic Mirrors (96" x 48" max size)

PG: Plate Glass (Floor) (100" x 48 max size)

LG: Laminated Glass (96" x 48" max size)

T: Tempered Mirror (100" x 48" max size)

VC: Vinyl Clad (100" x 48")

U717-1: Bottom "J" Channel only

U717-2: Bottom & Top "J" Channel

U717-4: Four Sided "J" Channel

When mirrors are fabricated with multiple pieces of glass, size of each piece must be specified.

Mirrors are always ordered Width x Height

Fabricated to a tolerance of ± 1/8"

U717-1: Mount the bottom channel at desired or specified location. Place a level across the channel to make sure mirror will be level. Place glass and masonite strips (vertical) in channel and check with level again. Clips are recommended on the top for securing mirror properly. (SCL-J: stainless steel clips)

U717-2: Mount the bottom "J" channel the same as above. Measure from the bottom "J" mold up height of mirror and strike a line. Mount top "J" the same way allowing 3/4" to lock glass in place. Place glass and masonite in channel and slide top "J" down to lock in place.

U717-4: Follow the same instructions for top and bottom style and add the two side "J" channel. The bottom reflective surface edge must be mounted 40" above finished floor to comply with ADA code, 4.19.6.

NOTES