

Job #:

Item #:

Quantity:

MOUNTING	HANDING	TYPE	SIZE	OTHER

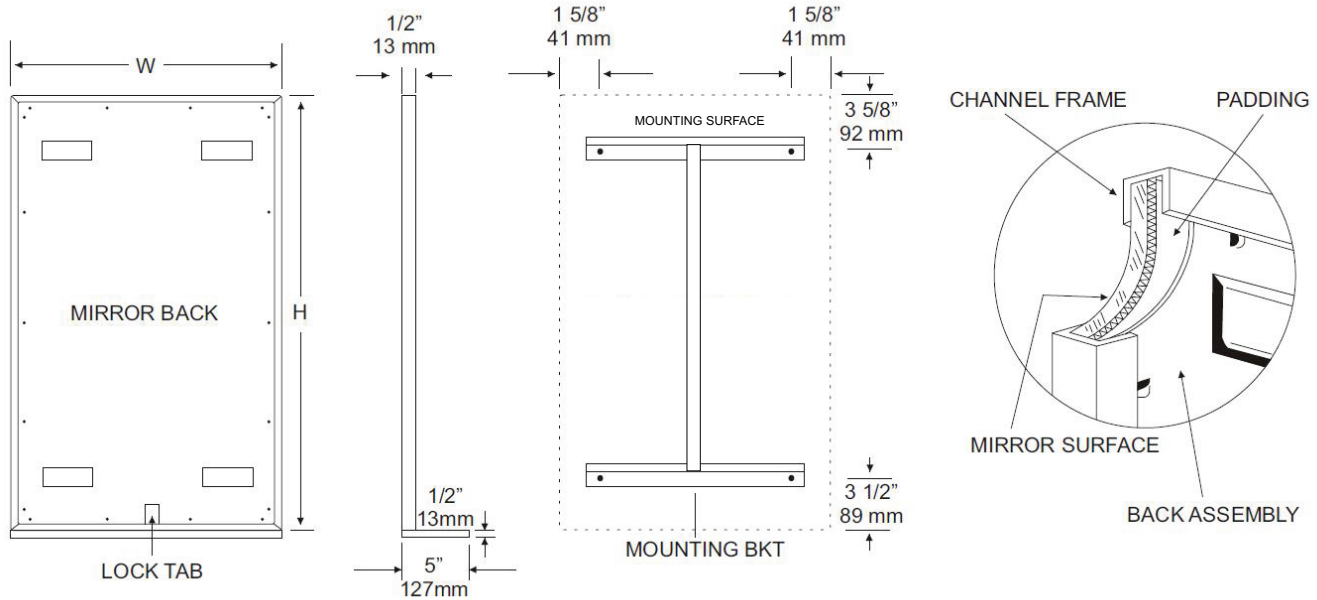

SPECIFICATIONS

Frame: Fabricated of type 304 #20 ga stainless steel, #4 satin finish. Roll formed 1/2" x 1/2" x 1/2" channel frame has mitered corners and secured with stainless steel rivet.

Mirror: 1/4" polished plate glass, coated and sealed with uniform electrolytic copper plating, guaranteed against silver spoilage for a period of 15 years.

Filler: Full size, 1/8" shock absorbing, water resistant, nonabrasive, polyethylene padding protects all concealed mirror surfaces.

Shelf: Type 304 #18 ga stainless steel with #4 satin finish. Shelf is 5"d x full mirror width. All edges are turned down 1/2" with front turned back 1/2" for rigidity and prevents injury. #18 ga support bracket is welded to both frame and shelf then ground smooth.

Back: #20 ga pre-plated galvanized steel, with embossed horizontal louver mounting brackets. Embossed theft resistant pressure activated clip lock device, locks mirror in place to wall hangers.

Hangers: Fabricated of #20 ga pre-plated steel galvanized steel with mounting points.

Mirrors conform to Federal Specifications DD-M-00411b & DD-g-541D.

Options:

VC: Safety Glass (Vinyl clad)

T: Tempered Glass

LG: Laminated Glass

PM: Plastic Acrylic

8B: #8 Reflective s/s

Max size-8B mirrors: 72" x 47 1/2"

Mirrors are always ordered Width x Height

Fabricated to a tolerance of ± 1/8"

INSTALLATION

Coordinate installation with architect / contractor for specific mounting location and height for each mirror application. Making sure "I" bracket is level, transfer all mounting point locations to wall surface from drawing. Secure brackets with proper fasteners for each application. Slide mirror down over horizontal brackets until clip lock secures mirror in place. Mirror can only be removed by inserting tool through hole at bottom of frame depressing clip. This will allow mirror to slide up over brackets. Fillers are available if mirrors are mounted above and below tile line. (U004 Filler) filler material will match mirror frame to form a one piece construction.

To meet ADA Code, bottom edge of reflective surface can be no higher than 40" above finished floor. (4.19.6) Full length mirrors may be used for universal application when installed in correct locations.

Abrasive cleaners & chloric solutions should not be used on mirrors. Discoloring and /or scratching of frame and reflective surface may occur.

NOTES