

Job #:

Item #:

Quantity:

MOUNTING	HANDING	TYPE	SIZE	OTHER

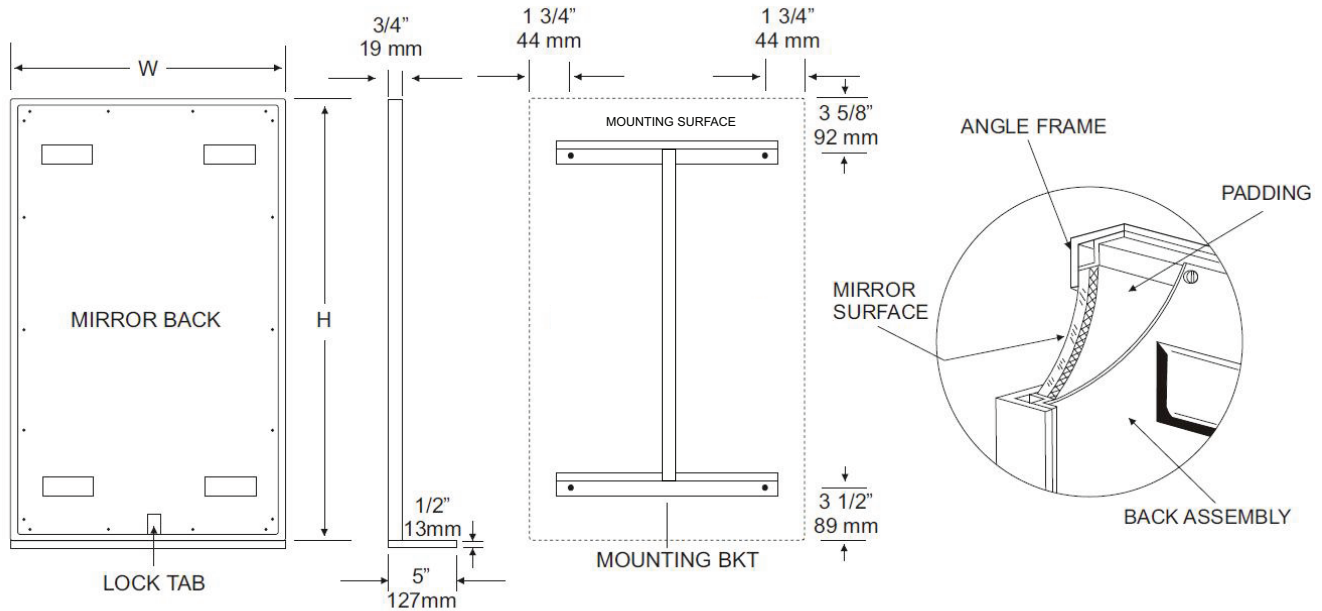

### SPECIFICATIONS

**Frame:** Fabricated of type 304 #18 ga stainless steel, #4 satin finish. 3/4" x 3/4" frame with welded mitered corners are ground and polished smooth. #22 ga concealed "Z" channel is spot welded to inner perimeter of frame for reinforcement and greater rigidity.

**Mirror:** 1/4" polished plate glass, coated and sealed with a uniform electrolytic copper plating, guaranteed against silver spoilage for a period of 15 years.

**Shelf:** Type 304 #18 ga stainless steel with #4 satin finish. Shelf is 5"D x full width of mirror. All edges are turned down 1/2" with front edge turned back 1/2" for rigidity and prevents possible injury. #18 ga support bracket is welded to both frame and shelf then ground smooth.

**Filler:** 3/16" thick full size, shock absorbing, water resistant, non-abrasive polyethylene padding protects all concealed mirror surfaces.

**Back:** #20 ga pre-plated galvanized steel, with embossed horizontal louver mounting brackets. Embossed theft resistant pressure activated clip lock device, locks mirror in place to wall hangers. Back is secured to frame with concealed Phillips head screws every 6".

**Hangers:** Fabricated of #20 ga pre-plated galv. steel.

**Mirrors conform to Federal Specifications DD-M-00411b & DDg- 541D.**

**Options:**

**VC:** Safety Glass(Vinyl clad)

**T:** Tempered Glass

**LG:** Laminated Glass

**PM:** Plastic Acrylic

**8B:** #8 Reflective s/s

**Rec. max size-8B mirrors:** 72"W x 47 1/2"H

**Mirrors are always ordered Width x Height**

**Fabricated to a tolerance of ± 1/8"**

### INSTALLATION

**Coordinate installation with architect / contractor for specific mounting location and height for each mirror application. Making sure "I" bracket is level, transfer all mounting point locations to wall surface from drawing. Secure brackets with proper fasteners for each application. Slide mirror down over horizontal brackets until clip lock secures mirror in place. Mirror can only be removed by inserting tool through hole at bottom of frame depressing clip. This will allow mirror to slide up over brackets. Fillers are available if mirrors are mounted above and below tile line. (U004 Filler) filler material will match mirror frame to form a one piece construction.**

**To meet ADA Code, bottom edge of reflective surface can be no higher than 40" above finished floor. (4.19.6) Full length mirrors may be used for universal application when installed in correct locations.**

**Abrasive cleaners & chloric solutions should not be used on mirrors. Discoloring and /or scratching of frame and reflective surface may occur.**

### NOTES