

MOUNTING	HANDING	TYPE	SIZE	OTHER

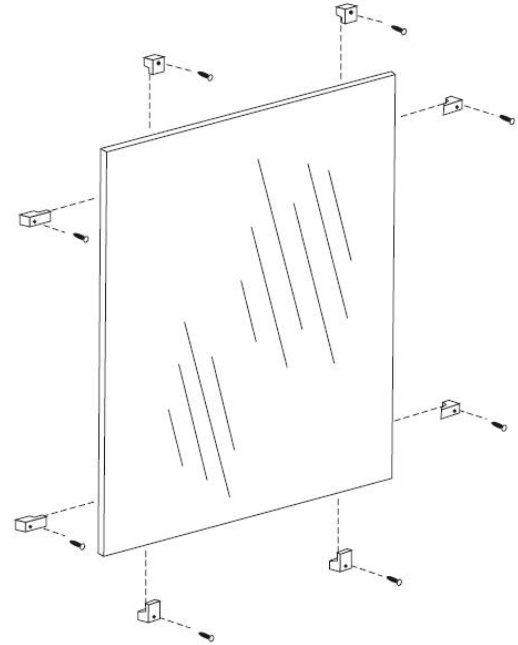
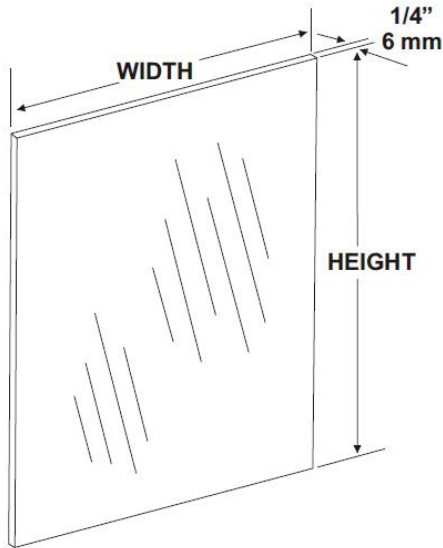

SPECIFICATIONS

Mirror: Frameless mirror is fabricated of #1 quality, 1/4" thick polished plate glass, silver coated and sealed with a uniform coating of electrolytic copper plating. Mirrors are provided with a smooth polished edges for safety. Plate glass mirrors are guaranteed against silver spoilage for a period of 15 years and conform to Federal Specifications DD-G-451D. Recommended size one piece glass is 100" x 48"

OPTIONAL SURFACES & SIZES:

- PM:** Plastic Mirrors (96" x 48" max size)
- LG:** Laminated Glass (96" x 48" max size)
- BE:** Beveled Edge Mirror: 1/4" plate glass w/ 1/2" Beveled Edge (72" x 60" max size)
- VC:** Vinyl Clad (120" x 48")

***NOTE:** For oversized mirrors, recommend using U717 "J" mold style mirrors (Bottom, Top & Bottom or 4 sided) See U717 tech data sheet for more information.

MOUNTING OPTIONS:

- CL:** Lucite Mirror Clips: (6 clips per pack)
- SCL:** Stainless Steel Clips: (6 clips per pack)
- BCL:** Lucite Mirror clips for beveled edge mirrors.

These Mirrors are always ordered Width x Height

Frameless mirrors are fabricated to a tolerance of ± 1/16"

INSTALLATION

Provide an area on wall surface at desired or specified location. Select the proper clips for mounting. Mount the bottom clips approx. 1" in from each side of the overall width of the mirror. Place a level across the clips to make sure mirror will be level. Place glass on clips and check with level again. Follow same procedures for other clips. For oversized glass, it is recommended to have a minimum of a bottom "J" mold style mounting frame.

***Note:** Recommend 4 sq ft of glass per 1 pack of plastic clips. 8 sq ft of glass for stainless clips. The bottom reflective surface edge must be mounted 40" above finished floor to comply with ADA code, 4.19.6.

NOTES