

U526-SM
NAPKIN/TAMPON DISPENSER
SURFACE MOUNTED

Job #:

Item #:

Quantity:

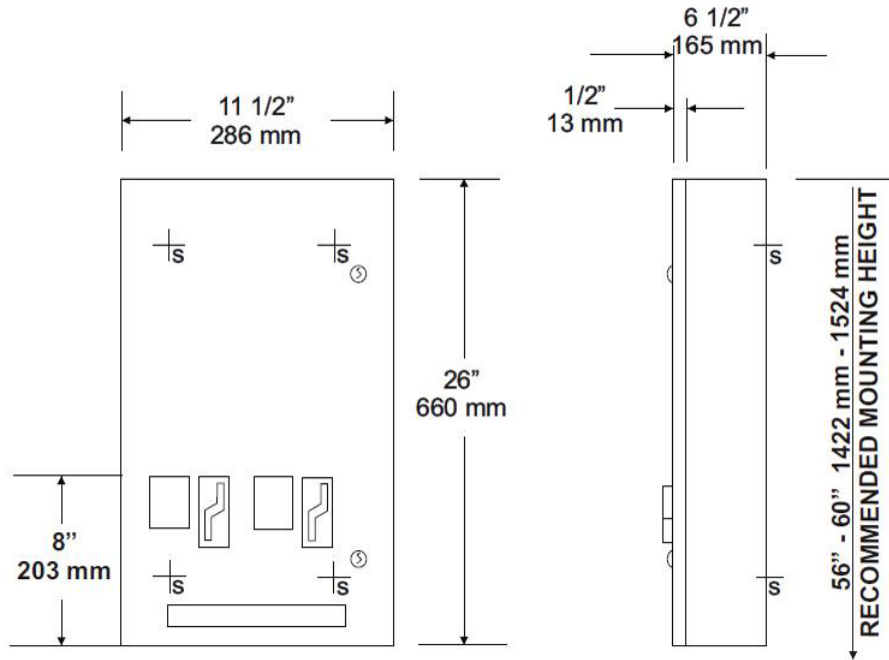

Door: Fabricated of type 304 #18 ga stainless steel with #4 satin finish. Door has 1/2" returns for rigidity.

Body: Fabricated of type 304 #22 ga stainless steel with a #4 satin finish.

Coin Mechanisms: Two independent, trouble free turn knob mechanisms, with an "EMPTY" indicator that does not allow coins to be inserted into mechanism when product has been depleted. Operational with one hand with less than 5 lbs (22.2n) of force without tight grasping. Can be operated with palm, elbow or forearm if user has a physical impairment. (Free, .5, .10, .25, .50)

Hinges: Full length, heavy duty, stainless steel piano type hinge.

Locks: Pin tumbler, commercial quality, keyed like all other A & J cabinets. *(Coin box keyed differently then the door for security)

Overall Size: 11 1/2"W x 26"H x 6 1/2"D

292mm x 660mm x 165mm

Capacity: Napkins: 30, Tampons: 27

Verify Coinage: Napkin _____ Tampon _____

Recommended Package Sizes:

Napkins:

Min: 2 5/8"W x 4 1/8"L x 3/4"H

Max: 3 1/8"W x 4 1/2"L x 1 1/8"H

Tampons:

Min: 5/8" Dia. x 4 1/4"L

Max: 3/4" Dia. 5 1/8"L

Coordinate installation with architect or contractor to avoid interference with pipes, vents, etc... Open cabinet and transfer mounting points to wall surface after location is verified. Drill pilot holes and secure with proper fasteners per each application. Fill each chute with the proper products and make certain to place weights on the top product. Test operation of mechanism and dispensing of product before securing cabinet. Each cabinet comes with a parts list for ordering replacement parts if ever required.

***Note:** Adjustable flange can be added to make unit Semi-Recessed.

When mounted properly, unit will comply with ADA Code 4.27.4

NOTES