

U526 Installation Instruction Sheet

NTD-001	Turn knob with set screw
NTD-002	HL100 lock & key
NTD-003	Coin & denomination label
NTD-526-011	Mounting plate
NTD-526-012	Two stack finger plate
NTD-526-013	Flipper horn
NTD-526-014	Tampon rotor
NTD-526-015	Tampon weight
NTD-526-016	Napkin weight
NTD-526-10N	Coin mechanism for napkin dispenser only (.10, .25, .50 & Free)
NTD-010	Coin mechanism for tampon dispenser (.10, .25, .50 & Free)
NTD-526-017	Coin box

Overall Size: 13 1/2"W x 28"H x 6 1/2"D

Wall Opening: 11 3/4"W x 26 1/4"H x 1"D (min) to 6" (max)

Capacity: Napkins 30, Tampons 27

Package Sizes Dispensed:

Napkins:

Min: 2 5/8"W x 4 1/8"L x 3/4"H

Max: 3 1/8"W x 4 1/2"L x 1 1/8"H

Tampons:

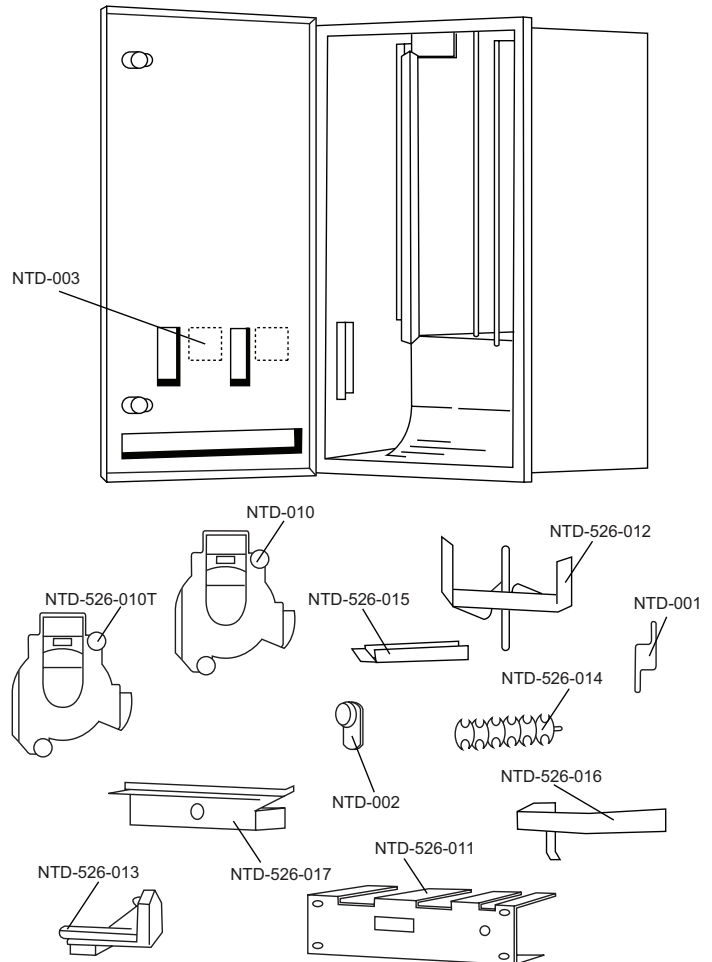

INSTALLATION & TROUBLESHOOTING

Recessed Units: Secure frame to wall opening. Slide unit through frame to desired depth and secure in place with four (4) #10 screws provided. If rear mounting holes cannot be used, it may be necessary to drill holes in sides of unit as needed

Recommended Mounting Height: Finished floor to turn knob mechanism 40" for ADA compliance.

Troubleshooting

My Unit Will Not Accept Coins: Check to see if chutes are empty. This unit has an automatic empty indicator which prevents coins from entering slot when chute is empty.

The Packages Get Hung Up In Chute: Check packages for size as recommended by manufacturer. Make sure packages have not been wet, bent, crushed or are out of shape in any other manner.

Check if weight is being used properly over packages to be dispensed in each chute. Check chutes and front door to see if it has been vandalized or tampered with. In many cases chutes are damaged when units are vandalized. If chutes cannot be straightened, they should be replaced.

FEATURES & INSTRUCTIONS

1. Peel off coinage labels
2. Separate coin box lock from door locks
3. Two separate mechanisms that can operate independently of one another and at different coinages. If one is damaged or breaks, it can be individually replaced.
4. Weights will indicate on turn knob mechanisms when chutes are empty and will not allow coins to be inserted.
5. High storage capacity

Refilling The Vendor

Napkins: Remove weight from napkin chute and fill with napkin packages. Replace weight on top of napkins and store reserve napkins in storage area.

Tampons: Remove weight from tampon chute and fill with tampons. Replace weight on top of tampons and store reserve tampons in storage area.

Ordering Labels: When ordering labels or mechanisms specify product and coinage for proper labels.