



# U852H

Seat Cover Dispenser

Revision 03/11

JOB #:

ITEM #:

QUANTITY:

MOUNTING	HANDING	TYPE	SIZE	OTHER

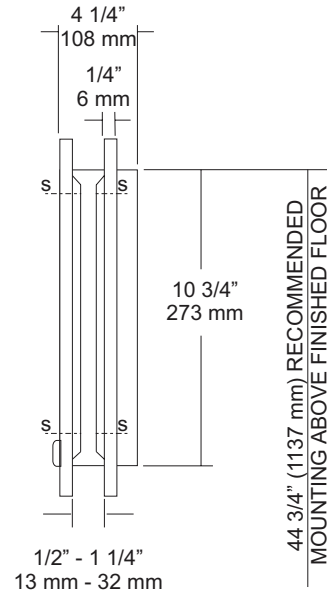
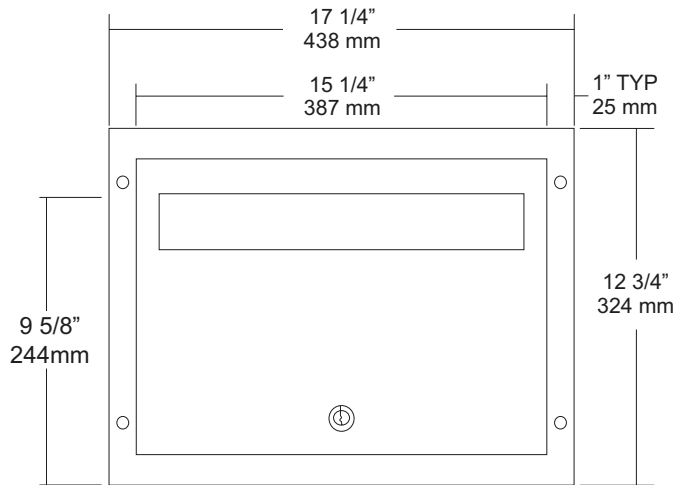

44 3/4" (1137 mm) RECOMMENDED MOUNTING ABOVE FINISHED FLOOR

### SPECIFICATIONS

- Body:** Fabricated of #22 gauge stainless steel with a #4 satin finish on all exposed surfaces.
- Flange:** Fabricated of #22 gauge stainless steel with 1/4" returns without any exposed miters or welds. One flange is welded the other is adjustable.
- Door:** Fabricated of #22 gauge stainless steel with a #4 satin finish. Seat cover dispensing area is deburred and polished to avoid tearing of product. One side of unit can be opened for servicing.
- Hinge:** Full length stainless steel piano type hinge.
- Lock:** Pin tumbler, commercial quality keyed like all other AJW accessories.
- Overall Size:** 17 1/2"W x 12 3/4"H x 4 1/4"D  
445mm x 337mm x 108mm
- Wall Opening:** 15 3/4"W x 11 1/4"H  
400mm x 324mm
- Will fit partitions** 1/2" - 1 1/4"
- Capacity:** 500 seat covers per side

### INSTALLATION

Provide required wall opening at desired or specified location. Coordinate installation with contractor or architect. Unlock cabinet, remove adjustable flange and place unit in wall opening. Secure fixed flange to wall surface with proper fasteners. Repeat same procedure for adjustable flange. Fill dispenser with seat covers and lock cabinet.

### NOTES